



通用汽油机零部件图册

PARTS CATALOGUE FOR LIFAN GENERAL GASOLINE ENGINE



2V77F-A

重庆力帆内燃机有限公司
Chongqing Lifan Power Co.,Ltd.

说 明 PREFACE

2V77F-A 通用汽油机是重 力帆内燃机有限公司采用国内外先 技 自行研制开 的双缸、四冲程、制 冷汽 油机。机具有 先 、构 凑、性能可靠、修方便、使用 、速方便等特点，其配套用途广泛，是 、旅游 、野外作 、 所、建筑机械、 机械、林 机械等 域的理想配套 力。

《2V77F-A 通用汽油机零部件 册》是我公司 了方便用 精心 制而成， 册涵盖了零部件的基本情 况，如 ： 、名称、数量等，用 零件 参考本册，若与 机不同之 ，以 机 准。

《2V77F-A 通用汽油机零部件 册》的所有版 属于重 力帆内燃机有限公司，任何 体和个人不得非法 翻印 或复制。如有更改，恕不另行通知。

Combine with all the specialty and advantages of the same models at home and abroad, 2V77F-A, being of 4-stroke, double cylinder with force air-cooled type, is one of the newly gasoline engines developed by our Co. It is characterized by advanced design, compact structure, reliable performance, convenient service, low fuel consumption and easy regulation. The engine is widely used as ideal power in many fields such as generating set, tour, open working, public place of entertainment, construction machine, agricultural machinery, etc.

For the sake of customer's convenience, we carefully compile the **PART CATALOGUE FOR 2V77F-A ENGINE**, which covers the main information of parts, such as illustrations, names, quantities, etc. Please refer to this book when you order the parts. If any difference in the book from the actual engine status, please do as per the real.

The copyright of this catalogue belongs to Lifan Power Co., Ltd. Any group or individual is forbidden to reprint or copy any item from it. The catalogue is subject to change without notice.

重庆力帆内燃机有限公司

Chongqing Lifan Power Co., Ltd.

二零零六年六月第一版(Jun, 2006 First Edition)

编制		校核		标准化		英文校对		批准	
----	--	----	--	-----	--	------	--	----	--

目 录
(INDEX TO ENGINE GROUP)

E-1 曲轴箱总成·····	1
CRANKCASE ASSY	
E-2 曲轴箱盖组件·····	3
CRANKCASE COVER ASSY	
E-3 气缸头、气缸头盖总成（一）·····	5
CYLINDER HEAD & CYLINDER HEAD COVER ASSY（I）	
E-4 气缸头、气缸头盖总成（二）·····	7
CYLINDER HEAD & CYLINDER HEAD COVER ASSY（II）	
E-5 曲轴、活塞连杆总成·····	9
CRANKSHAFT, PISTON, CONNECTING	
E-6 凸轮轴装配组合、气门摇臂组合·····	10
COMBINATION OF CAM SHAFT & VALVE ROCKER	
E-7 化油器总成·····	12
CARBURETOR ASSY	
E-8 空气滤清器总成·····	15
AIR CLEANER ASSY	
E-9 消声器组件（选配）·····	16
MUFFLER	

E-10	反充起动机部件.....	17
	RECOIL STARTER	
E-11	调速控制系统.....	19
	REGULATING CONTROL SYSTEM	
E-12	飞轮部件.....	20
	FLYWHEEL	
E-13	点火线圈组件.....	21
	IGNITION COIL	
E-14	起动控制盒总成.....	22
	STARTING MOTOR CONTROL BOX ASSY	
E-15	整流器（选配）.....	23
	RECTIFIER	
E-16	贴花.....	24
	EMBLEM	

E-1 曲轴箱总成 CRANKCASE ASSY

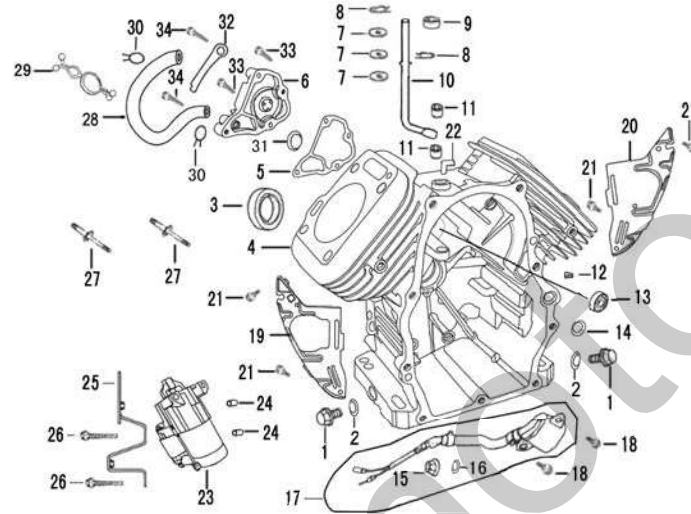

序号 S/N	零 部 件 代 号 Part No.	零 部 件 名 称	Description	数 量 Quantity	备 注 Remark
1	11212/2V77F	放油螺塞	Drain plug	2	
2	11213/2V77F	放油螺塞垫圈	Wahser, drain plug	2	
3	13180/2V77F	曲轴油封 38×58×8	Oil seal, crankshaft,38×58×8	1	
4	11100/2V77F	曲轴箱组合	Crankcase	1	
5	12354/2V77F	迷宫盖板密封垫	Gasket, labyrinth gland	1	
6	12353/2V77F	迷宫盖板	Gland, labyrinth	1	
7	26329/2V77F	调速摆杆垫片	Washer	3	
8	26321/168F	调速摆杆锁夹	Split pin	2	
9	26390/2V77F	调速摆杆油封 8×14×5	Oil seal, regulating sway bar	1	
10	26311/2V77F	调速摆杆	Regulating sway bar	1	
11	GB/T12764	滚针轴承 φ8×10×12	Roller bearing φ8×10×12	2	
12	13142/2V77F	油道堵塞	Plug, oil passage	1	
13	GB/T279	轴承 6003	Bearing 6003	1	
14	11124/2V77F	O 型密封圈 φ13.5×2.5	O-ring	1	
15	GB/T6177.1	螺母 M10	Nut M10	1	
16	GB/T3452.1	O 型密封圈 φ13×1.4	O-ring	1	
17	37810/173F	机油传感器	Oil sensor	1	

E-1 曲轴箱总成 CRANKCASE ASSY

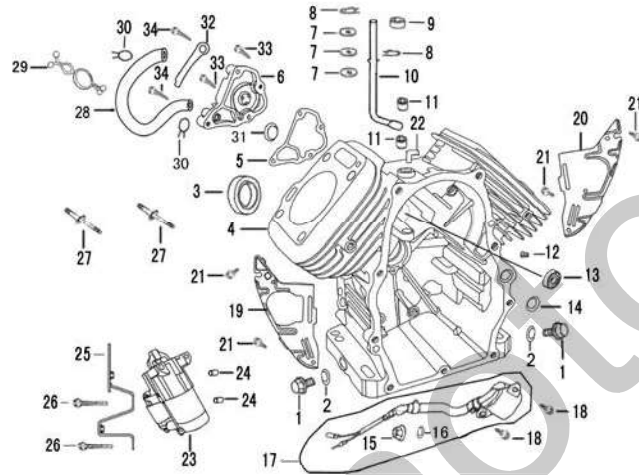

序号 S/N	零部件代号 Part No.	零部件名称	Description	数量 Quantity	备注 Remark
18	GB/T16674.1	螺栓 M6×16	Bolt M6×16	2	
19	19821/2V77F	曲轴箱侧板 I	Slide plate, crankcase I	1	
20	19825/2V77F	曲轴箱侧板 II	Slide plate, crankcase II	1	
21	GB/T16674.1	螺栓 M6×12	Bolt M6×12	4	
22	20150/2V77F	废气嘴组合	Nipple, exhaust	1	
23	34700/2V77F	起动机总成	Motor, starting	1	
24	34713/2V77F	起动机定位销 φ10×12	Dowel pin, Motor, starting	2	
25	34750/2V77F	起动机连接架组合	Connecting member set, starting motor	1	
26	28652/2V77F	起动机螺栓 M8×110	Bolt M8×110	2	
27	34911/2V77F	点火线圈双头螺栓	Stud	2	
28	20152/2V77F	废气管	Pipe, exhaust	1	
29	20130/2V77F	废气管管夹组合	Clamp set, exhaust pipe	1	
30	20154/2V77F	废气管管夹	Clamp, exhaust pipe	2	
31	154532V77F	阀片	Valve piece	1	
32	322132V77F	压线板	Clamper, cord	1	
33	GB/T16674.1	螺栓 M6×16	Bolt M6×16	2	
34	GB/T16674.1	螺栓 M6×30	Bolt M6×30	2	

E-2 曲轴箱盖组件 CRANKCASE COVER ASSY

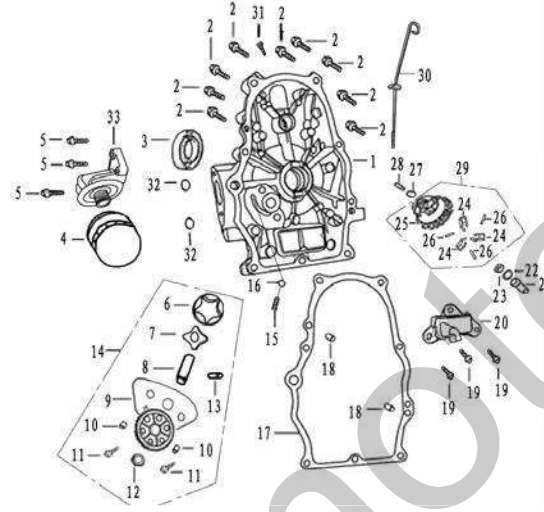

序号 S/N	零 部 件 代 号 Part No.	零 部 件 名 称	Description	数 量 Quantity	备 注 Remark
1	I1311/2V77F	曲轴箱盖	Crankcase cover	1	
2	I2256/1P64FV	气缸头螺栓 M8×50	Bolt M8×50	9	
3	I3180/2V77F	曲轴油封 38×58×8	Oil seal, crankshaft	1	
4	I5410/2V77F	机油滤清器总成	Oil filter Assy	1	
5	GB/T16674.1	螺栓 M6×25	Bolt M6×25	3	
6	I5115/2V77F	机油泵外转子	Rotor, outer, oil pump	1	
7	I5114/2V77F	机油泵内转子	Rotor, inner, oil pump	1	
8	I5116/2V77F	机油泵轴	Shaft, oil pump	1	
9	I5112/2V77F	机油泵盖	Cover, oil pump	1	
10	I5118/2V77F	机油泵定位销	Set pin, oil pump	2	
11	GB/T70.1	螺钉 M6×16	Screw M6×16	2	
12	I5126/2V77F	从动齿轮嵌件	Inserter, driven gear	1	
13	I5029/2V77F	机油泵轴内转子传动销		1	
14	I5100/2V77F	机油泵总成	Oil pump Assy	1	
15	I5168/2V77F	弹簧	Spring	1	
16	GB/T308	(泻油) 钢球 S φ9.5	Ball S φ9.5	1	
17	I1119/2V77F	曲轴箱垫片	Gasket, crankcase	1	

E-2 曲轴箱盖组件 CRANKCASE COVER ASSY

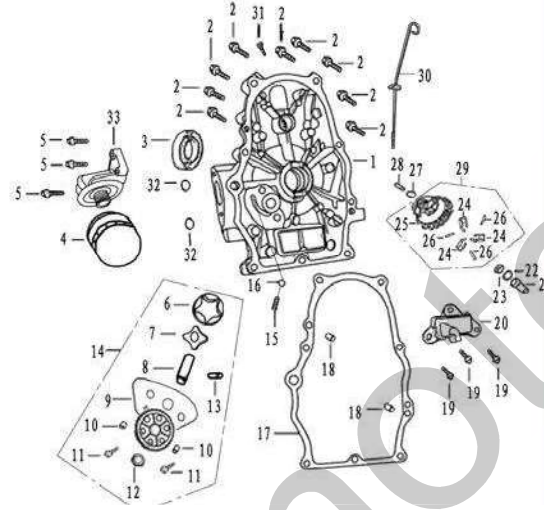

序号 S/N	零 部 件 代 号 Part No.	零 部 件 名 称	Description	数 量 Quantity	备 注 Remark
18	11118/168F	定位销 $\phi 8 \times 14$	Set pin	2	
19	GB/T5789	螺栓 M6 \times 16	Bolt M6 \times 16	3	
20	15450/2V77F	机油滤网组合	Gauze set	1	
21	25131/2V77F	调速滑套	Sliding sleeve	1	
22	25132/168F	调速滑套垫片	Washer	1	
23	25164/173F	调速轴卡圈	Snap ring	1	
24	25141/2V77F	调速飞块	Flying block	3	
25	25121/2V77F	调速从动齿轮	Driven gear, regulator	1	
26	25163/2V77F	飞块销	Pin	3	
27	25165/173F	调速从动齿轮垫片	Washer, driven gear	1	
28	25151/2V77F	调速轴	Regulating shaft	1	
29	25120/2V77F	调速从动齿轮组件	Driven gear, regulator assy	1	
30	15610/2V77F	机油尺组件	Dipstick with seal	1	
31	11113/2V77F	油孔螺塞	Plug	1	
32	15442/2V77F	O 型密封圈 $\phi 13 \times 2$	O-ring $\phi 13 \times 2$	2	
33	15412/2V77F	机油滤清器座	Oil-filter housing	1	

E-3 气缸头 气缸头盖总成 I CYLINDER HEAD & CYLINDER HEAD COVER ASSY I

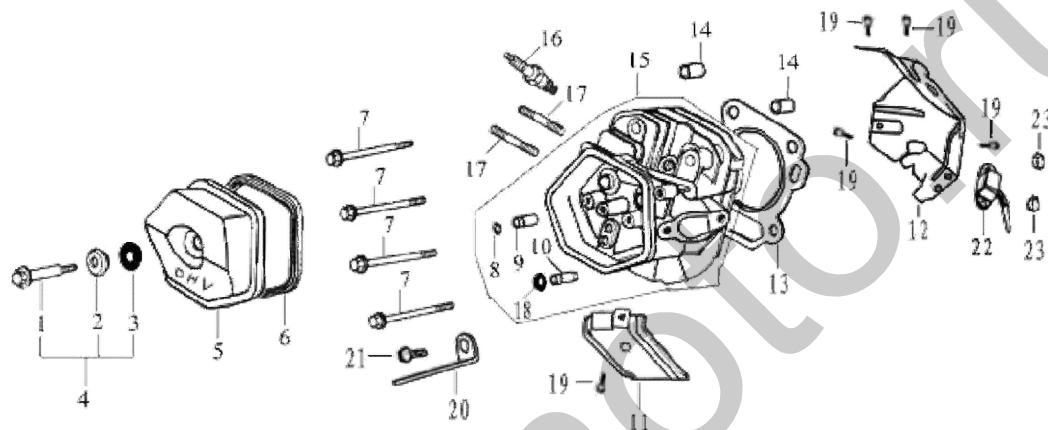

序号 S/N	零部件代号 Part No.	零部件名称	Description	数量 Quantity	备注 Remark
1	12411/173F	气缸头盖螺栓	Bolt	1	
2	12412/173F	气缸头盖螺栓垫圈	Washer	1	
3	12421/173F	橡胶圈	Rubber seal	1	
4	12410/173F	气缸头盖螺栓组件	Bolt	1	
5	12310/2V77F	气缸头盖 I	Cylinder head cover Assy I	1	
6	12312/173F	气缸头盖密封圈	Gasket, cylinder head cover	1	
7	12256/173F	气缸头螺栓	Bolt	4	
8	12219/173F	排气门导管卡圈	Circip	1	
9	12215/173F	排气门导管	Exhaust valve guide	1	
10	12214/173F	进气门导管	Intake valve guide	1	
11	19711/2V77F	导风罩	Deflector	1	
12	19721/2V77F	下导风罩 I	Lead wind cover I	1	
13	12220/2V77F	气缸头密封垫	Gasket, cylinder head	1	
14	12218/2V77F	气缸头定位销 $\phi 12 \times 16$	Set pin $\phi 12 \times 16$	2	
15	12210/2V77F	气缸头组合 I	Cylinder head Assy I	1	
16	34200/173F	火花塞 F6TC	Spark plug F6TC	1	
17	12253/2V77F	排气口双头螺栓	Stud	2	

E-3 气缸头 气缸头盖总成 I CYLINDER HEAD & CYLINDER HEAD COVER ASSY I

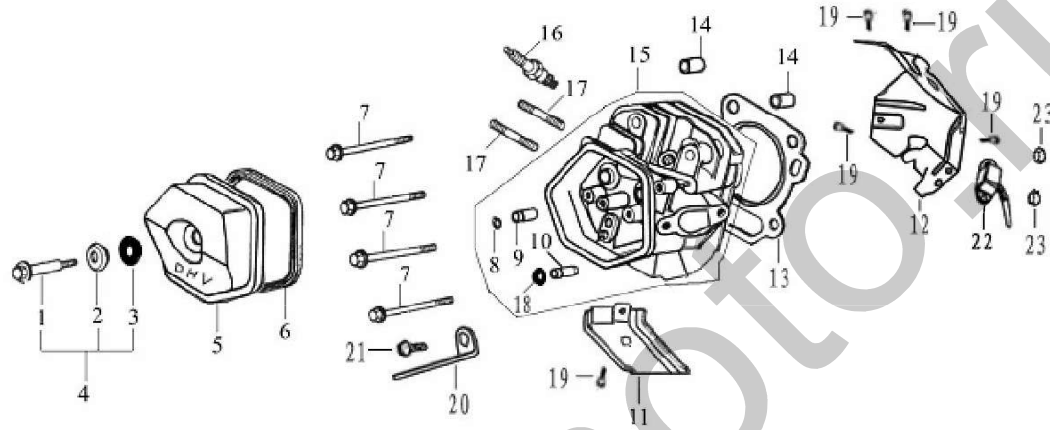

序号 S/N	零部件代号 Part No.	零部件名称	Description	数量 Quantity	备注 Remark
18	14730/173F	挡油罩	Seal	1	
19	GB/T16674.1	螺栓 M6×12	Bolt M6×12	6	
20	41113/2V77F	吊环支架	Ring support	1	
21	GB/T16674.1	螺栓 M8×16	Bolt M8×16	1	
22	37850/2V77F	单向导通器	Diode	1	
23	GB/T6177.1	螺母 M6	Nut M6	2	

E-4 气缸头 气缸头盖总成 II CYLINDER HEAD & CYLINDER HEAD COVER ASSY II

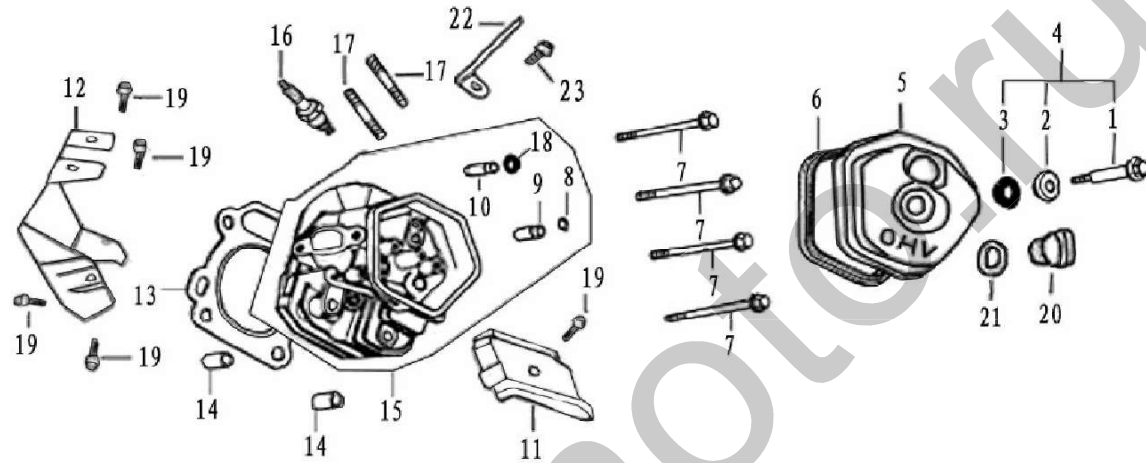

序号 S/N	零部件代号 Part No.	零部件名称	Description	数量 Quantity	备注 Remark
1	12411/173F	气缸头盖螺栓	Bolt	1	
2	12412/173F	气缸头盖螺栓垫圈	Washer	1	
3	12421/173F	橡胶圈	Rubber seal	1	
4	12410/173F	气缸头盖螺栓组件	Bolt	1	
5	12336/2V77F	气缸头盖 II	Cylinder head cover Assy II	1	
6	12312/173F	气缸头盖密封圈	Gasket, cylinder head cover	1	
7	12256/173F	气缸头螺栓	Bolt	4	
8	12219/173F	排气门导管卡圈	Circip	1	
9	12215/173F	排气门导管	Exhaust valve guide	1	
10	12214/173F	进气门导管	Intake valve guide	1	
11	19711/2V77F	导风罩	Deflector	1	
12	19723/2V77F	下导风罩 II	Lead wind cover II	1	
13	12220/2V77F	气缸头密封垫	Gasket, cylinder head	1	
14	12218/2V77F	气缸头定位销 $\phi 12 \times 16$	Set pin, $\phi 12 \times 16$	2	
15	12230/2V77F	气缸头组合 II	Cylinder head Assy II	1	
16	34200/173F	火花塞 F6TC	Spark plug F6TC	1	
17	12253/2V77F	排气口双头螺栓	Stud	2	

E-4 气缸头 气缸头盖总成 II CYLINDER HEAD & CYLINDER HEAD COVER ASSY II

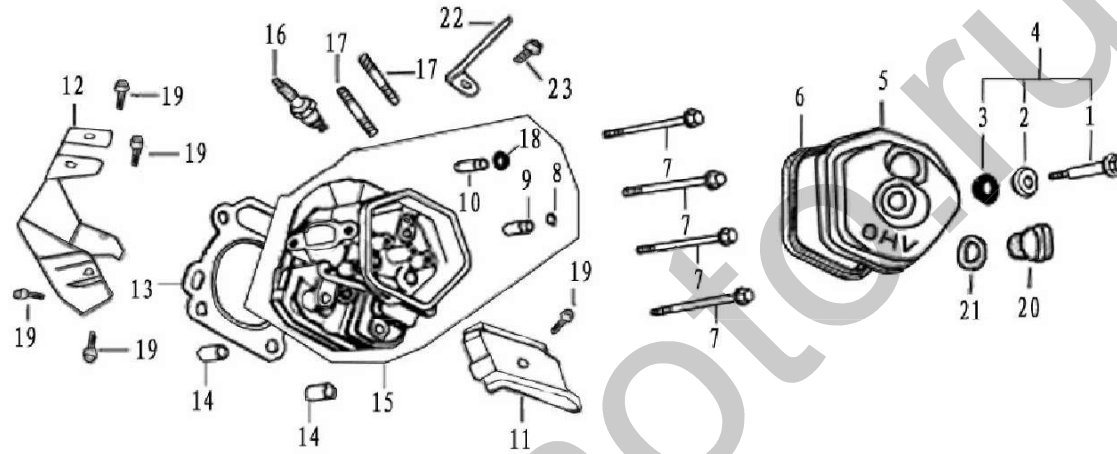

序号 S/N	零部件代号 Part No.	零部件名称	Description	数量 Quantity	备注 Remark
18	14730/173F	挡油罩	Seal	1	
19	GB/T16674.1	螺栓 M6×12	Bolt M6×12	5	
20	15651/2V77F	机油塞	Oil plug	1	
21	15652/2V77F	机油塞密封圈	Seal	1	
22	41113/2V77F	吊环支架	Ring support	1	
23	GB/T16674.1	螺栓 M8×16	Bolt M8×16	1	

E-5 曲轴 活塞连杆总成 CRANKSHAFT, PISTON, CONNECTING

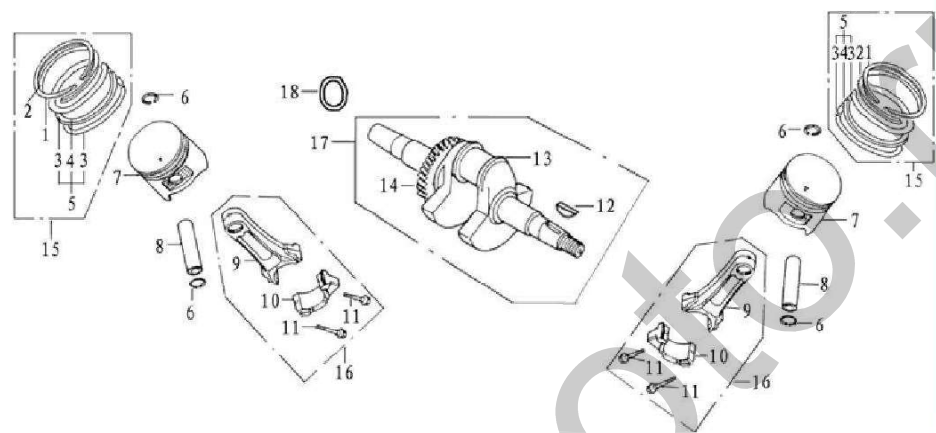

序号 S/N	零部件代号 Part No.	零部件名称	Description	数量 Quantity	备注 Remark
1	13311/2V77F	活塞环 I	Piston ring I	2	
2	13312/2V77F	活塞环 II	Piston ring II	2	
3	13322/2V77F	侧环	Side rail	4	
4	13321/2V77F	衬簧	Expander	2	
5	13320/2V77F	油环组合	Scraper ring set	2	
6	13222/173F	活塞销挡圈	Piston pin circlip	4	
7	13211/2V77F	活塞	Piston	2	
8	13221/2V77F	活塞销	Piston pin	2	
9	13131/2V77F	连杆	Connecting rod	2	
10	13132/2V77F	连杆盖	Connecting rod cover	2	
11	13133/173F	连杆螺栓	Bolt	4	
12	13118/173F	半圆键	Wood ruff key	1	
13	13111/2V77F	曲轴	Crankshaft	1	
14	14211/2V77F	正时主动齿轮	Timing driving gear	1	
15	13300/2V77F	活塞环组合	Piston ring set	2	
16	13130/2V77F	连杆组合	Connecting rod assy	2	
17	13110/2V77F	曲轴组合	Crankshaft assy	1	
18	13119/2V77F	曲轴调整垫片	Adjusting washer	1	

E-6 凸轮轴装配组合 气门摇臂组合 COMBINATION OF CAM SHAFT & VALVE ROCKER

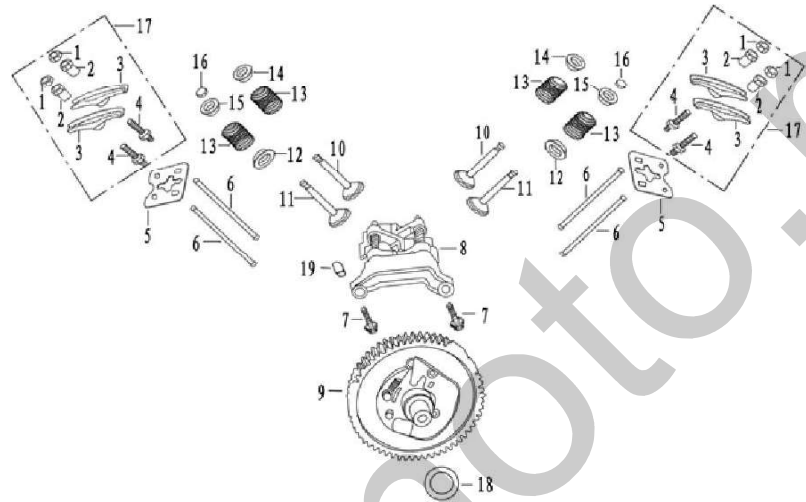

序号 S/N	零 部 件 代 号 Part No.	零 部 件 名 称	Description	数 量 Quantity	备 注 Remark
1	14416/173F	气门间隙调节螺母	Lock nut	4	
2	14413/173F	摇臂轴座销	Sleeve	4	
3	14411/173F	气门摇臂	Valve rocker	4	
4	14415/173F	气门间隙调节螺栓	Adjusting bolt for valve gap	4	
5	14261/173F	推杆导架	Pusher guide	2	
6	14250/2V77F	推杆组合	Pusher	4	
7	GB/T16674.1	螺栓 M6×20	Bolt M6×20	2	
8	14450/2V77F	下摇臂装配组合	Rocker arm Assy,lower	1	
9	14100/2V77F	凸轮轴装配组合	Camshaft assy	1	
10	14711/182F	进气门	Intake valve	2	
11	14721/182F	排气门	Exhaust valve	2	
12	14753/173F	排气门弹簧下座	Spring retainer, exhaust valve	2	
13	14755/173F	气门弹簧	Valve spring	4	
14	14757/173F	排气门弹簧座	Spring seat, exhaust valve	2	
15	14751/173F	进气门弹簧座	Spring seat, intake valve	2	
16	14758/173F	排气门顶帽	Cap	2	
17	14410/173F	气门摇臂装配组合	Valve rocker assy	2	

E-6 凸轮轴装配组合 气门摇臂组合 COMBINATION OF CAM SHAFT & VALVE ROCKER

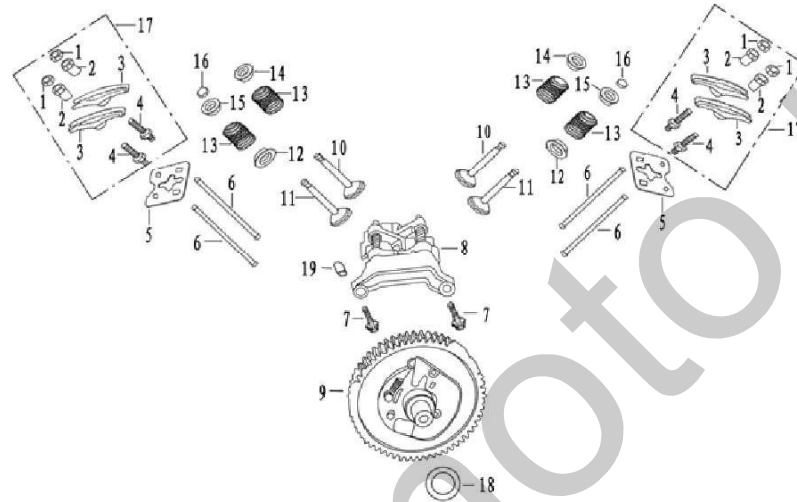

序号 S/N	零 部 件 代 号 Part No.	零 部 件 名 称	Description	数 量 Quantity	备 注 Remark
18	14117/2V77F	凸轮轴调整垫片	Adjusting washer	1	
19	11118/173F	定位销 $\phi 8 \times 12$	Set pin $\phi 8 \times 12$	1	

E-7 化油器总成 进气管总成 CARBURETOR ASSY & INLET PIPE ASSY

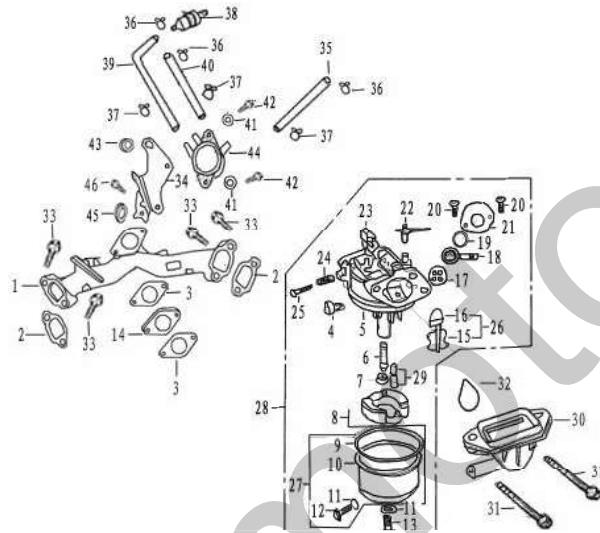

序号 S/N	零部件代号 Part No.	零部件名称	Description	数量 Quantity	备注 Remark
1	17311/2V77F	进气管	Inlet pipe	1	
2	12254/2V77F	进气口垫片	Inlet gasket	2	
3	16142/2V77F	化油器垫片	Carburetor gasket	2	
4	16421/2V77F	怠速调整螺钉	Idle adjustment screw	1	
5	16250/2V77F	化油器混合室体	Mixture chamber body	1	
6	16251/2V77F	主喷油管	Main nozzle	1	
7	16254/2V77F	主喷油嘴	Main jet	1	
8	16230/2V77F	浮子组合	Float	1	
9	16219/2V77F	浮子室密封垫	Float chamber gasket	1	
10	16211/2V77F	浮子室	Float chamber	1	
11	16216/2V77F	浮子室放油螺钉垫圈	Washer	2	
12	16215/2V77F	浮子室放油螺钉	Float chamber drain Screw	1	
13	16213/2V77F	底部螺钉	Screw	1	
14	16141/2V77F	化油器接块	Connecting block	1	
15	16331/2V77F	阻风门	Choke	1	

E-7 化油器总成 进气管总成 CARBURETOR ASSY & INLET PIPE ASSY

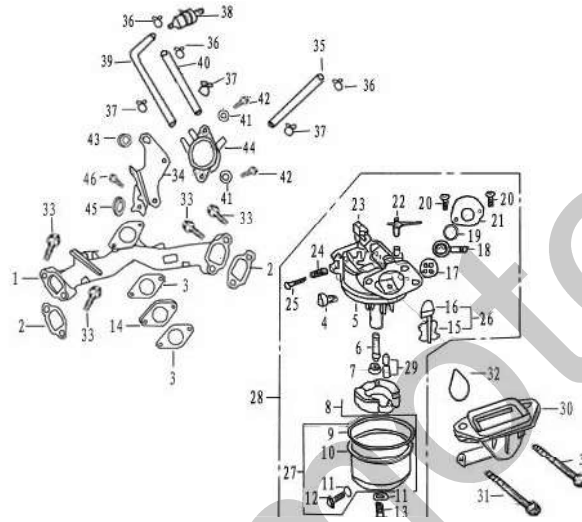

序号 S/N	零部件代号 Part No.	零部件名称	Description	数量 Quantity	备注 Remark
16	16332/2V77F	阻风门轴	Choke stem	1	
17	16312/2V77F	油门控制臂密封圈	Airproof washer	1	
18	16311/2V77F	油门控制臂	Throttle lever	1	
19	16313/2V77F	油门控制臂钢垫片	Washer	1	
20	GB/T16674.1	螺钉 M4	Screw M4	2	
21	16314/2V77F	油门控制臂固定盖	Cover	1	
22	16148/2V77F	阻风门开关	Choke switch	1	
23	16280/2V77F	节气门组合	Throttle unit	1	
24	16422/2V77F	混合比调整螺钉弹簧	Spring, mixture adjustment screw	1	
25	16425/2V77F	混合比调整螺钉	Mixture adjustment screw	1	
26	16330/2V77F	阻风门组合	Choke unit	1	
27	16210/2V77F	浮子室组合	Float chamber	1	
28	16100/2V77F	化油器总成	Carburetor Assy	1	
29	16240/2V77F	浮子油针组合	Float needle	1	
30	17190/2V77F	空滤器安装支架组合	Bracket, air cleaner	1	

E-7 化油器总成 进气管总成 CARBURETOR ASSY & INLET PIPE ASSY

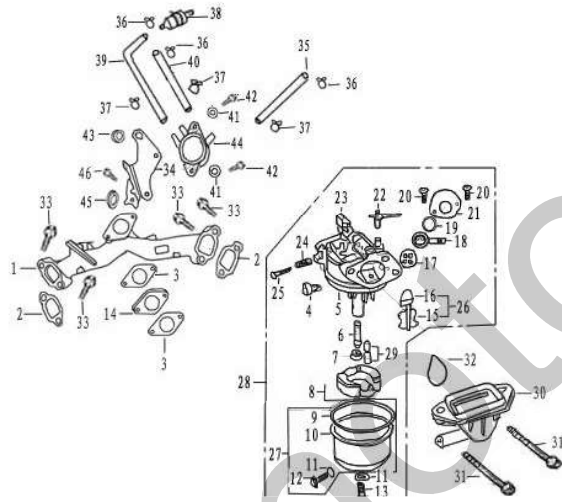

序号 S/N	零部件代号 Part No.	零部件名称	Description	数量 Quantity	备注 Remark
31	16143/2V77F	化油器螺栓 M6×120	Bolt M6×120	2	
32	17332/2V77F	进气管密封圈	gasket, inlet pipe	1	
33	12256/1P64FV	螺栓 M8×50	Bolt M8×50	4	
34	16731/2V77F	汽油泵支撑板		1	
35	16735/2V77F	汽油泵出油管	Outlet pipe, fuel pump	1	
36	16936/2V77F	油管夹 I	Clamp, pipe I	3	
37	16937/2V77F	油管夹 II	Clamp, pipe II	3	
38	16870/2V77F	燃油过滤器组件		1	
39	16734/2V77F	汽油泵进油管	Inlet pipe, fuel pump	1	
40	16737/2V77F	汽油泵负压管	Vacuum pipe, fuel pump	1	
41	16733/2V77F	汽油泵垫片	Washer, fuel pump	2	
42	GB/T16674.1	螺栓 M6×12	Screw M6×12	2	
43	16732/2V77F	垫圈 I	Washer I	1	
44	16700/2V77F	汽油泵总成	Fuel pump Assy	1	
45	16738/2V77F	垫圈 II	Washer II	1	
46	GB/T16674.1	螺栓 M6×16	Bolt M6×16	1	

E-8 空气滤清器总成 AIR CLEANER ASSY

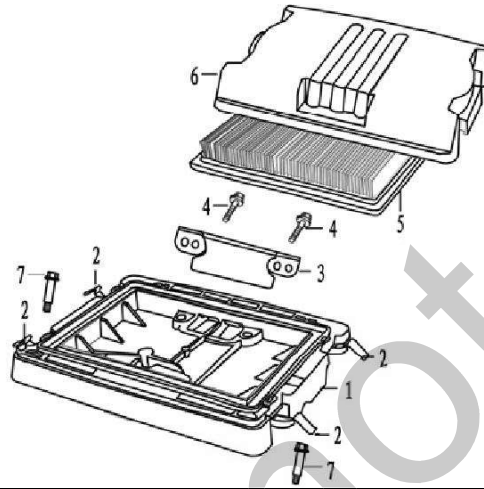

序号 S/N	零部件代号 Part No	零部件名称	Description	数量 Quantity	备注 Remark
1	17131/2V77F	空滤器座	Air cleaner housing	1	
2	17150/2V77F	空滤器卡箍	Clamp, air cleaner	4	
3	17134/2V77F	空滤器通风盖板		1	
4	GB/T16674.1	螺栓 M6×25	Bolt M6×25	2	
5	17130/2V77F	滤芯组件	Filter element	1	
6	17111/2V77F	空滤器盖	Air cleaner cover	1	
7	17151/2V77F	空滤器螺栓	Bolt, air cleaner	2	

E-9 消声器组件 MUFFLER (OPTION)

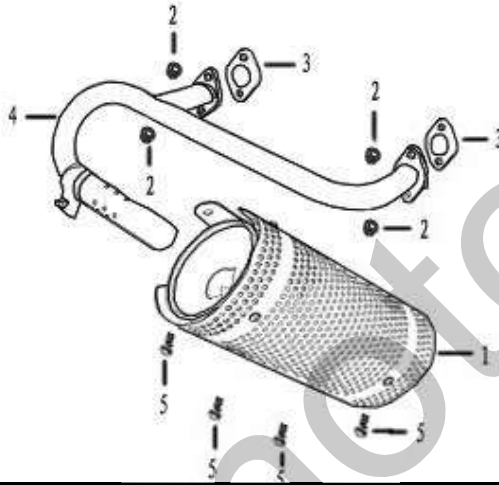

序号 S/N	零部件代号 Part No	零部件名称	Description	数量 Quantity	备注 Remark
1	18100/2V77F	消声器总成	Muffler assy	1	
2	GB/T6170	螺母 M8	Nut M8	4	
3	12255/2V77F	排气口垫片	Exhaust pipe gasket	1	
4	18111/2V77F	排气管	Exhaust pipe	1	
5	GB/T16674.1	螺栓 M8×16	Screw M8×16	4	

E-10 反冲起动机部件 RECOIL STARTER

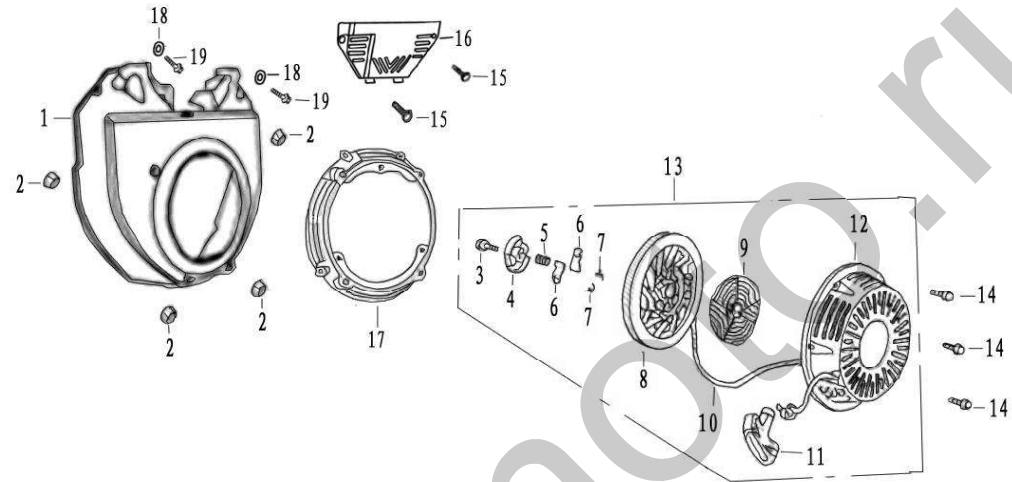

序号 S/N	零部件代号 Part No	零部件名称	Description	数量 Quantity	备注 Remark
1	19710	风扇罩组件	Fan hood assy	1	
2	GB/T6177.1	螺母 M6	Nut M6	4	
3	27315/173F	轴位螺钉	Set screw	1	
4	27341/173F	弹簧盖	Spring lid	1	
5	27311/173F	摩擦弹簧	Friction spring	1	
6	27331/173F	棘爪	Ratchet	2	
7	27312/173F	棘爪弹簧	Ratchet spring	2	
8	27351/182F	起动机卷轴	Starter rolls	1	
9	27319/182F	盘簧	Spiral spring	1	
10	27313/168F	拉绳	Rope	1	
11	27361/168F	拉手	Pulling handle	1	
12	27380/182F	外壳组件	Casing	1	
13	27300/182F	反冲起动机	Recoil starter	1	
14	GB/T16674.1	螺栓 M6×8	Bolt M6×8	3	
15	GB/T5282	自攻螺钉 st4.2×19	Screw st4.2×19	2	
16	19714/2V77F	挡风板	Wind plate	1	
17	27320	拉盘护罩组合		1	

E-10 反冲起动器部件 RECOIL STARTER

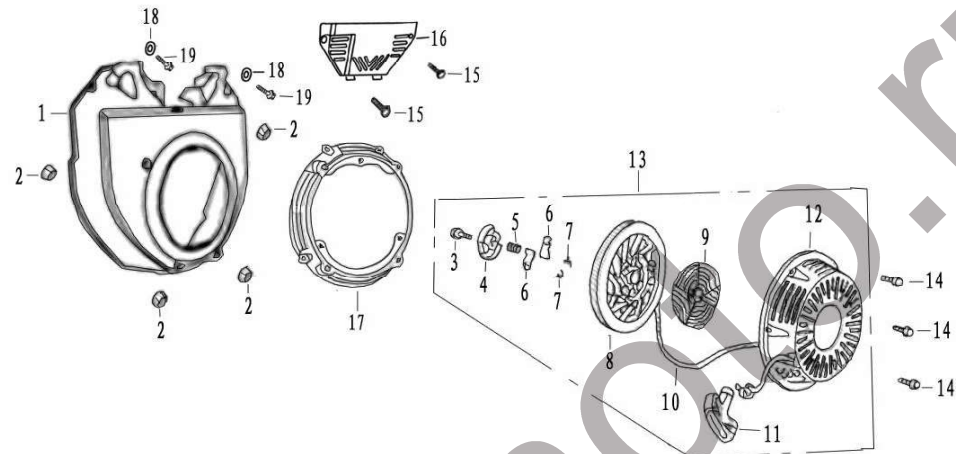

序号 S/N	零部件代号 Part No	零部件名称	Description	数量 Quantity	备注 Remark
18	16733/2V77F	汽油泵垫片	Gasoline pump gasket	2	
19	GB/T16674.1	螺栓 M6×16	Bolt M6×16	2	

E-11 调速控制系统 REGULATING CONTROL SYSTEM

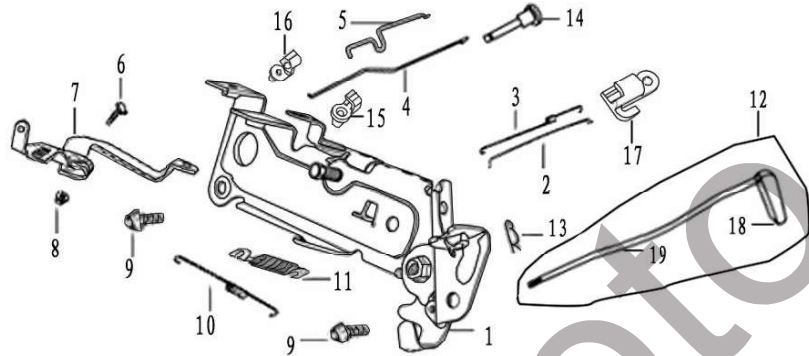

序号 S/N	零部件代号 Part No	零部件名称	Description	数量 Quantity	备注 Remark
1	26420/2V77F	调速支撑板组件	Regulating board	1	
2	26341/2V77F	调速拉杆	Pulling rod	1	
3	26363/2V77F	复位弹簧	Back spring	1	
4	26336/2V77F	阻风门拉杆 I	Choke link I	1	
5	26338/2V77F	阻风门拉杆 II	Choke link II	1	
6	26362/2V77F	调速臂紧固螺栓	Lock bolt	1	
7	26331/2V77F	调速臂	Regulating arm	1	
8	GB/T6177.1	螺母 M6	Nut M6	1	
9	GB/T16674.1	螺栓 M8×16	Bolt M8×16	2	
10	26415/2V77F	调速弹簧	Regulating spring	1	
11	26364/2V77F	微调调速弹簧	Fine regulating spring	1	
12	26430/2V77F	手柄组合	Hand grip assy	1	
13	26321/168F	调速摆杆锁夹	Clamp, regulating sway bar	1	
14	16148/2V77F	阻风门开关	Switch, choke	1	
15	26335/2V77F	阻风门拉杆锁夹 II	Clamp, Choke link II	1	
16	26334/2V77F	阻风门拉杆锁夹 I	Clamp, Choke link I	1	
17	26342/2V77F	调速拉杆锁夹	Clamp, pulling rod	1	
18	26412/2V77F	手柄	Hand grip	1	
19	26413/2V77F	支架	Fixed mount	1	

E-12 飞轮部件 FLYWHEEL

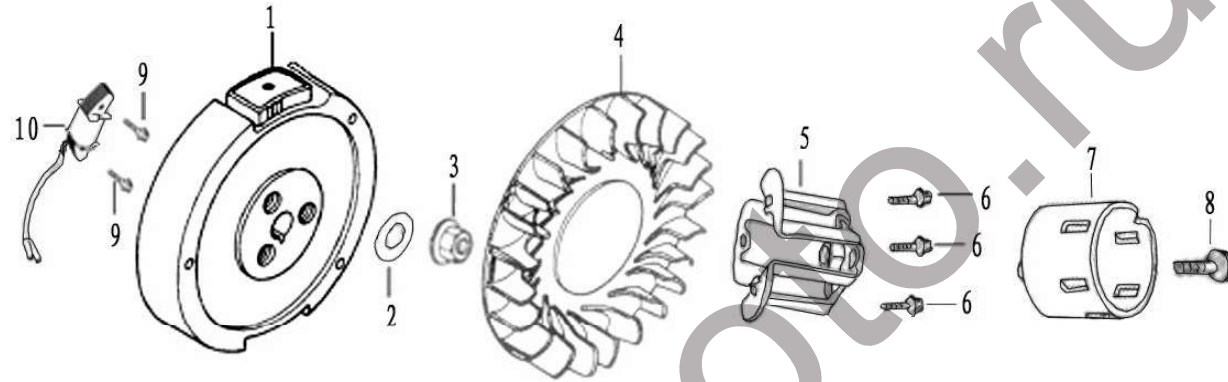

序号 S/N	零部件代号 Part No	零部件名称	Description	数量 Quantity	备注 Remark
1	27500/2V77F	飞轮组件	Flywheel	1	
2	27519/2V77F	飞轮垫片	Washer, flywheel	1	
3	27515/2V77F	飞轮螺母 M20×2	Nut M20×2	1	
4	19722/2V77F	飞轮风扇	Flywheel fan	1	
5	19720	飞轮风扇压板组件		1	
6	GB/T16674.1	螺栓 M8×16	Bolt M8×16	3	
7	27371	起动套	Starting flange	1	
8	27373	起动套连接螺栓 M12×1.5×28	Bolt M12×1.5×28	1	
9	GB/T16674.1	螺栓 M6×30	Bolt M6×30	2	
10	31250/2V77F	充电定子组件		1	

E-13 点火线圈组件 IGNITION COIL

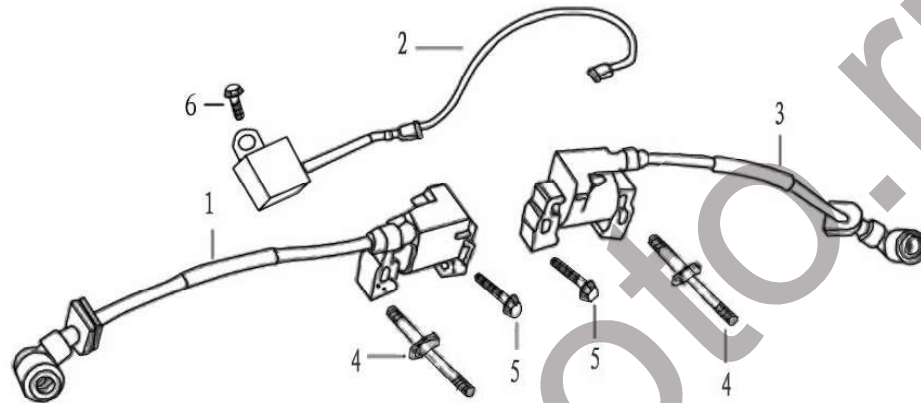

序号 S/N	零部件代号 Part No	零部件名称	Description	数量 Quantity	备注 Remark
1	34500/2V77F	点火线圈组件 I	Ignition coil assy I	1	
2	34400/2V77F	熄火单向器		1	
3	34800/2V77F	点火线圈组件 II	Ignition coil assy II	1	
4	34911/2V77F	点火线圈双头螺栓	Stud	2	
5	GB/T16674.1	螺栓 M6×25	Bolt M6×25	2	
6	GB/T16674.1	螺栓 M6×12	Bolt M6×12	1	

E-14 起动控制盒总成 (选用件) STARTING MOTOR CONTROL BOX ASSY (OPTION)

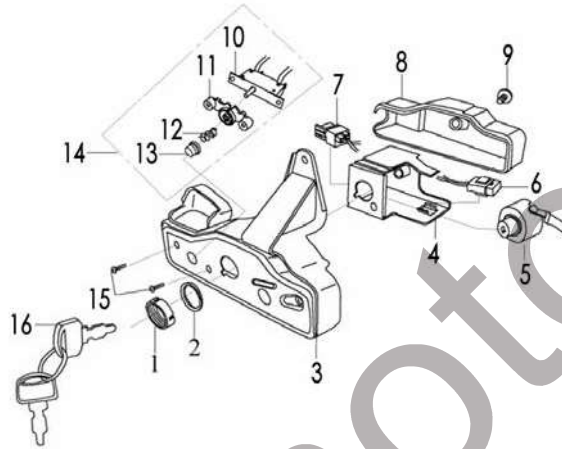

序号 S/N	零 部 件 代 号 Part No	零 部 件 名 称	Description	数 量 Quantity	备 注 Remark
1	35412/2V77F	锁紧圈	Clamp ring	1	
2	35413/2V77F	钥匙开关垫圈	Gasket	1	
3	27386/2V77F	控制盒前盖	Control front cover	1	
4	27387/2V77F	控制盒内支撑架	Fixed mount	1	
5	35411/2V77F	起动钥匙开关	Key switch	1	
6	35240/2V77F	保险	Fuse	1	
7	31112/2V77F	二极管	diode	1	
8	35341/2V77F	控制盒后盖	Control rear cover	1	
9	35345/2V77F	后盖连接螺栓	Attachment bolt	1	
10	28411/2V77F	线路保护器	Circuit protector	1	
11	28412/2V77F	线路保护器支架	Fixed mount	1	
12	28413/2V77F	弹簧	Spring	1	
13	28414/2V77F	线路保护器帽	Circuit protector map	1	
14	28410/2V77F	线路保护器组合	Circuit protector assy	1	
15	GB/T 818	十字半圆头螺钉 M3×12	Bolt M3×12	2	
16	35411/2V77F	钥匙	Key	1	

E-15 整流器（未购买起动控制盒时选用） RECTIFIER(OPTION)



序号 S/N	零部件代号 Part No	零部件名称	Description	数量 Quantity	备注 Remark
1	35412/2V77F	整流器	Rectifier	1	
2	GB/T 16674.1	螺栓 M6×12	Bolt M6×12	1	

E-16 贴花 EMBLEM



序号 S/N	零部件代号 Part No	零部件名称	Description	数量 Quantity	备注 Remark
1	68122	铭牌贴花	Emblem, nameplate	1	
2	68231/2V77F	阻风门开关贴花	Emblem, choke lever	1	
3	68129	型号贴花	Model label	1	
4	68123	手启动贴花	Emblem, hand	1	
5	68227/168F	阅读说明书贴花	Emblem, read owner's manual	1	
6	68124/168F	注意高温贴花	Emblem, Hi-temp	1	
7	68228/168F	注意一氧化碳贴花	Emblem, Notice: CO	1	
8	68211/168F	注意燃油贴花	Emblem, fuel	1	
9	68223/168F	空滤器保养贴花	Emblem, maintenance of air cleaner	1	
10	68225/168F	注意使用前加机油贴花	Emblem, Note: add oil before using	1	
11	68213/182F-AS	负极贴花	Emblem, "-" pole	1	
12	68212/182F-AS	正极贴花	Emblem, "+" pole	1	
13	68222/168F	加注机油贴花	Emblem, adding oil	1	
14	68226/2V77F	龟兔贴花	Emblem, tortoise and rabbit	1	



重庆力帆内燃机有限公司

Chongqing Lifan Power Co., Ltd.

重庆力帆内燃机有限公司
地址：重庆市南岸区海棠新街 38 号

电话：(023) 61663497
传真：(023) 61663498
邮编：400064
网址：www.lifan.com.cn
电子邮件：lfcc@vip.sina.com

Chongqing Lifan Power Co., Ltd.
Add: N0.38 Haitang New Street Nanan
District Chongqing

Tel: (023) 61663497
Fax: (023) 61663498
Postal code: 400064
[http:// www.lifan.com.cn](http://www.lifan.com.cn)
e-mail: lfcc@vip.sina.com

2006 年 6 月第一版