

说 明 PREFACE

LF188FD 通用汽油机是重庆力帆内燃机有限公司采用国内外先进技术自行研制开发的单缸、倾斜式、四冲程、强制风冷汽油机。该机具有设计先进、结构紧凑、性能可靠、维修方便、使用经济、调速方便等特点，其配套用途广泛，是发电、旅游、野外作业、娱乐场所、建筑机械、农业机械、林业机械等领域的理想配套动力。

《LF188FD 通用汽油机零部件图册》是我公司为了方便用户精心编制而成，该图册涵盖了零部件的基本情况，如：简图、名称、数量等，用户订购零件时请参考本册，若与实机不同之处，以实机为准。

《LF188FD 通用汽油机零部件图册》的所有版权属于重庆力帆内燃机有限公司，任何团体和个人不得非法翻印或复制。如有更改，恕不另行通知。

Combine with all the specialty and advantages of the same models at home and abroad, LF188FD, being of 4-stroke, single cylinder with force air-cooled type, is one of the newly gasoline engines developed by our Co. It is characterized by advanced design, compact struction, reliable performance, convenient service, low fuel consumption and easy regulation. The engine is widely used as ideal power in many fields such as generating set, tour, open working, public place of enterainment, construction machine, agricultural machinery, etc.

For the sake of customer's convenience, we carefully compile the **PART CATALOGUE FOR LF 188FD ENGINE**, which covers the main informations of parts, such as illustrations, names, quantities, etc. Please refer to this book when you order the parts. If any difference in the book from the actual engine status, please do as per the real.

The copyright of this catalogue belongs to Chongqing Lifan Power Co., Ltd. Any group or individual is forbidden to reprint or copy any item from it. The cotalogue is subject to change without notice.

重庆力帆内燃机有限公司

目 录

CONTENTS

E-1	曲轴箱总成.....	1
	CRANKCASE ASSY	
E-2	曲轴箱盖组件.....	2
	CRANKCASE COVER ASSY	
E-3	气缸头 气缸头盖总成.....	4
	CYLINDER HEAD & CYLINDER HEAD COVER ASSY	
E-4	曲轴 活塞连杆 平衡轴总成.....	6
	CRANKSHAFT, PISTON, CONNECTING & BALANCING SHAFT	
E-5	凸轮轴装配组合 气门摇臂组合.....	8
	COMBINATION OF CAM SHAFT & VALVE ROCKER	
E-6	化油器总成	10
	CARBURETOR ASSY	
E-7	燃油箱组成.....	12
	FUEL TANK ASSY	

--II--

E-1 曲轴箱总成 CRANKCASE ASSY

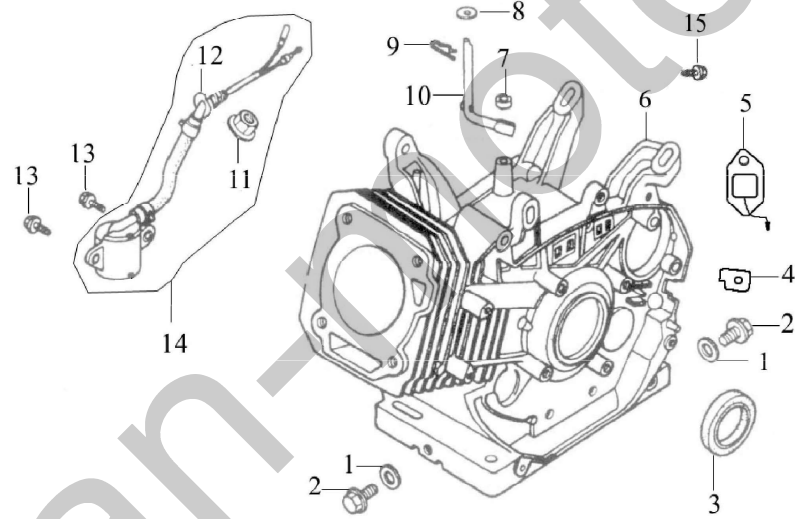

序号 S/N	零部件代号 Part No.	零部件名称	Description	数量 Quantity	备注 Remark
-----------	-------------------	-------	-------------	----------------	--------------

1	11116/173F	放油螺塞垫圈	Washer	2
2	11115/173F	放油螺塞	Drain plug	2
3	11120/182F	曲轴油封	Oil seal, crankshaft	1
4	11117/173F	曲轴箱橡胶圈	Seal	1
5	27500/168F	单向导通器	Diode	1
6	11100	曲轴箱组合	Crankcase	1
7	11130/182F	调速摆杆油封	Oil seal, regulating sway bar	1
8	26113/173F	调速摆杆垫片	Washer	2
9	26112/173F	调速摆杆锁夹	Split pin	1
10	26111/182F	调速摆杆	Regulating sway bar	1
11	GB/62-1988	螺母 M10	Nut M10	1
12	11119	O型密封圈 13×1.4	O-ring	1
13	GB/T16674-1996	螺栓 M6×14-F	Bolt M6×14-F	2
14	27400/173F	机油传感器	Oil sensor	1
15	GB/T16674-1996	螺栓 M6×12-F	Bolt M6×12-F	1

--1--

E-2 曲轴箱盖组件 CRANKCASE COVER ASSY

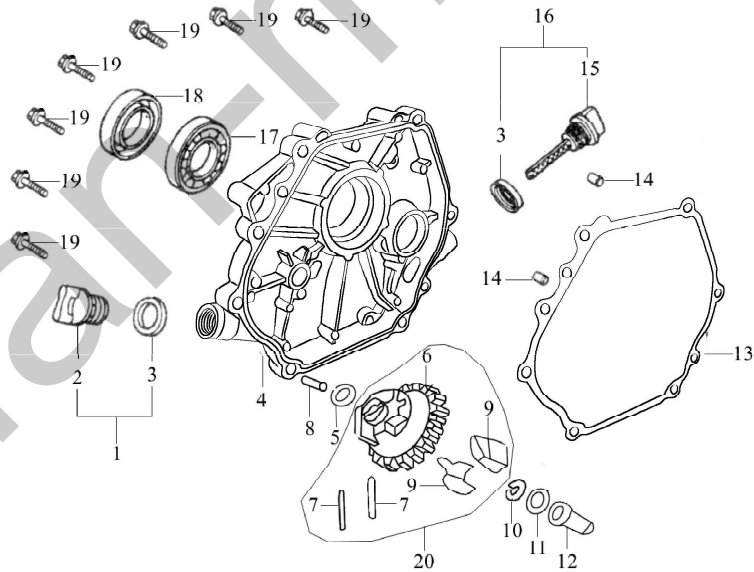

序号 S/N	零部件代号 Part No.	零部件名称	Description	数量 Quantity	备注 Remark
1	15520/173F	机油塞组件	Oil plug with Seal	1	
2	15521/173F	机油塞	Oil plug	1	
3	15512/173F	机油尺密封圈	Seal	2	
4	11211/182F	曲轴箱盖	Crankcase cover	1	
5	25118/173F	调速从动齿轮垫片	Washer, driven gear	1	
6	25111/182F	调速从动齿轮	Driven gear, regulator	1	
7	25116/173F	飞块销	Pin	2	
8	25115/173F	调速轴	Regulating shaft	1	
9	25114/182F	调速飞块	Flying block	2	
10	25117/173F	调速轴卡圈	Snap ring	1	
11	25113/168F	调速滑套垫片	Washer	2	
12	25112/173F	调速滑套	Sliding sleeve	1	

--2--

E-2 曲轴箱盖组件 CRANKCASE COVER ASSY

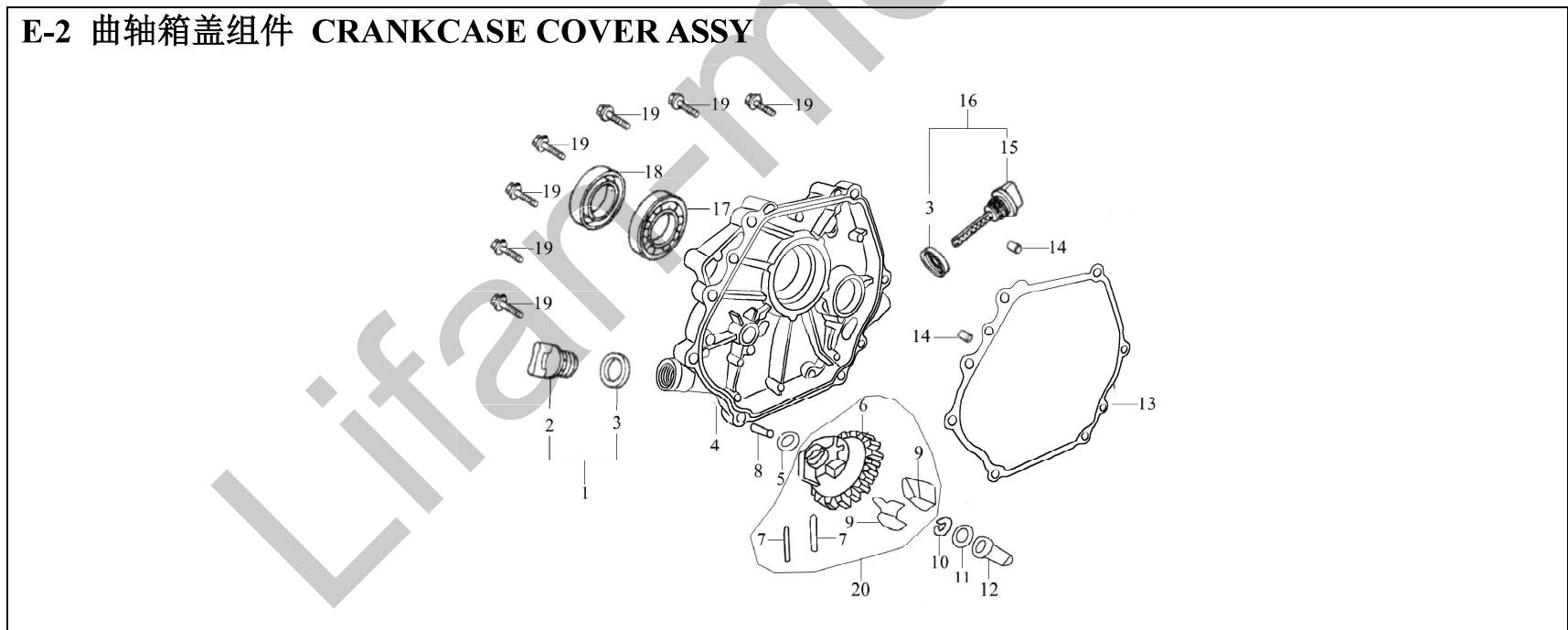

序号 S/N	零部件代号 Part No.	零部件名称	Description	数量 Quantity	备注 Remark
13	11114/182F	曲轴箱垫片	Gasket, crankcase	1	
14	11113/173F	定位销 $\Phi 8 \times 12$	Set pin $\Phi 8 \times 12$	2	
15	15511/173F	机油尺	Dipstick	1	
16	15510/173F	机油尺组件	Dipstick with seal	1	
17	GB276-89	轴承 6207	Bearing 6206	1	
18	11120/182F	曲轴油封	Oil seal, crankshaft	1	
19	GB/T16674-1996	螺栓 $M8 \times 35-F$	Bolt $M8 \times 35-F$	7	
20	25100/182F	调速从动齿轮组件	Driven gear, regulator assy	1	

--3--

E-3 气缸头 气缸头盖总成 CYLINDER HEAD & CYLINDER HEAD COVER ASSY

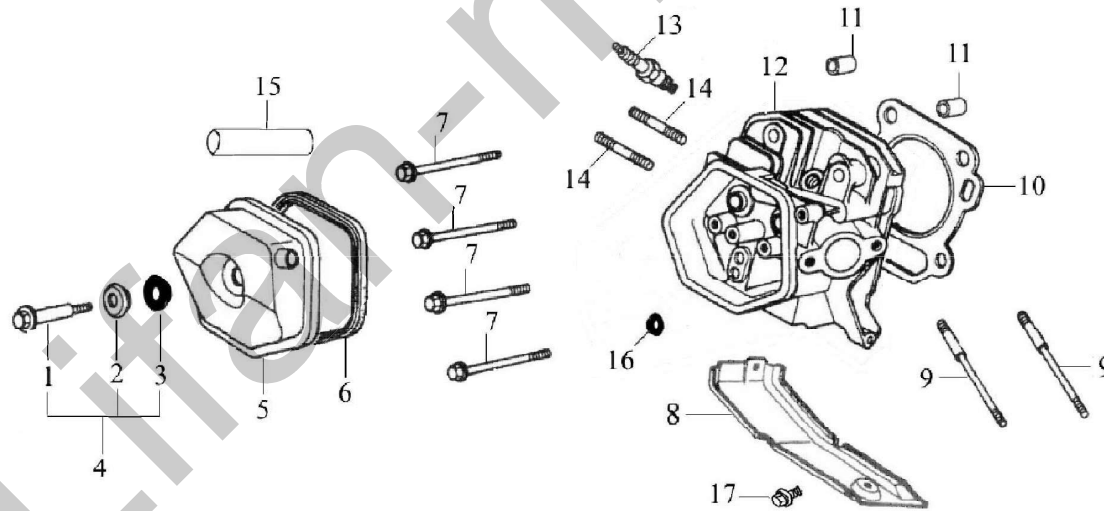

序号	零部件代号	零部件名称	Description	数量	备注
----	-------	-------	-------------	----	----

S/N	Part No.			Quantity	Remark
1	12221/173F	气缸头盖螺栓	Bolt	1	
2	12222/173F	气缸头盖螺栓垫圈	Washer	1	
3	12223/173F	橡胶圈	Rubber seal	1	
4	12220/173F	气缸头盖螺栓组件	Bolt	1	
5	12200/173F	气缸头盖组合	Cylinder head cover Assy	1	
6	12212/173F	气缸头盖密封圈	Gasket, cylinder head cover	1	
7	12118/173F	气缸头螺栓	Bolt	4	
8	19112/182F	下导风罩	Lead wind cover	1	
9	17218/182F	进气口双头螺栓 M6×M8×134.5	Stud M6×M8×134.5	2	
10	12121	气缸头密封垫	Gasket, cylinder head	1	
11	12100/173F	气缸头定位销	Set pin	2	

E-3 气缸头 气缸头盖总成 CYLINDER HEAD & CYLINDER HEAD COVER ASSY

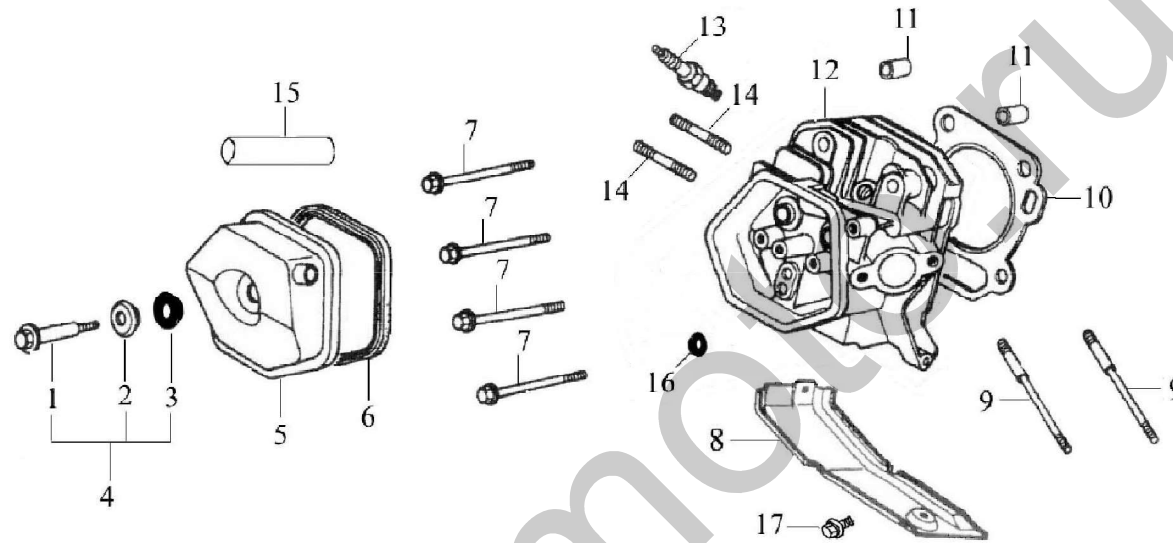

序号 S/N	零部件代号 Part No.	零部件名称	Description	数量 Quantity	备注 Remark
12	27100/182F	气缸头组合	Cylinder head Assy	1	
13	27100/168F	火花塞 F6RTC	Spark plug F6 RTCU	1	
14	18241/173F	排气口双头螺栓 M8×48.5	Stud M8×48.5	2	
15	17217/173F	通气管	Air duck	1	
16	14420/173F	挡油罩	Seal	1	
17	GB/T16674-1996	螺栓 M6×12-F	Bolt M6×12-F	1	

E-4 曲轴 活塞连杆 平衡轴总成 CRANKSHAFT, PISTON, CONNECTING & BALANCING SHAFT

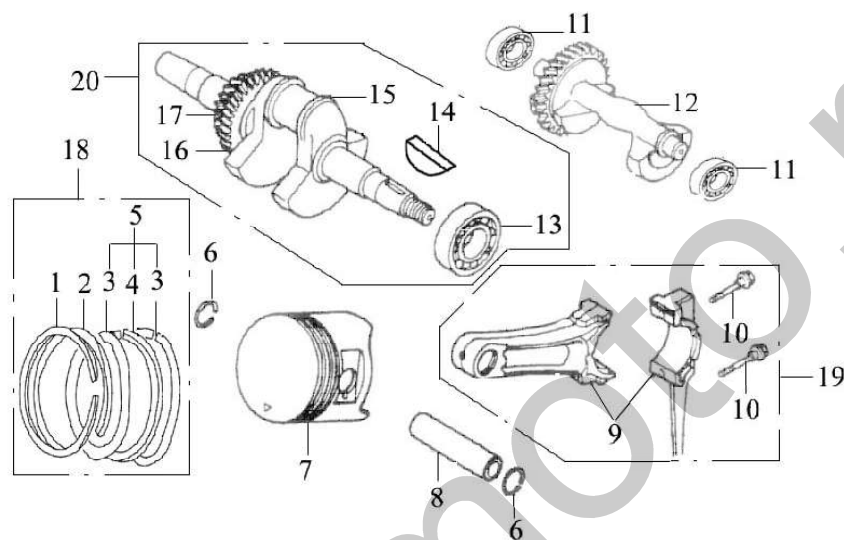

序号 S/N	零部件代号 Part No.	零部件名称	Description	数量 Quantity	备注 Remark
1	13411	活塞环 (一)	Piston ring (I)	1	
2	13412	活塞环 (二)	Piston ring (II)	1	
3	13422	侧环	Side rail	2	
4	13421	衬簧	Expander	1	
5	13420	油环组合	Scrapper ring set	1	
6	13313/182F	活塞销挡圈	Piston pin circlip	2	
7	13311	活塞	Piston	1	
8	13312	活塞销	Piston pin	1	
9	13200/182F	连杆	Shank	1	
10	13213/173F	连杆螺栓	Bolt	2	
11	GB276-89	轴承 6202	Bearing 6202	2	
12	13116/182F	平衡轴	Balancing shaft	1	
13	GB276-89	轴承 6207	Bearing 6207	1	

E-4 曲轴 活塞连杆 平衡轴总成 CRANKSHAFT, PISTON, CONNECTING & BALANCING SHAFT

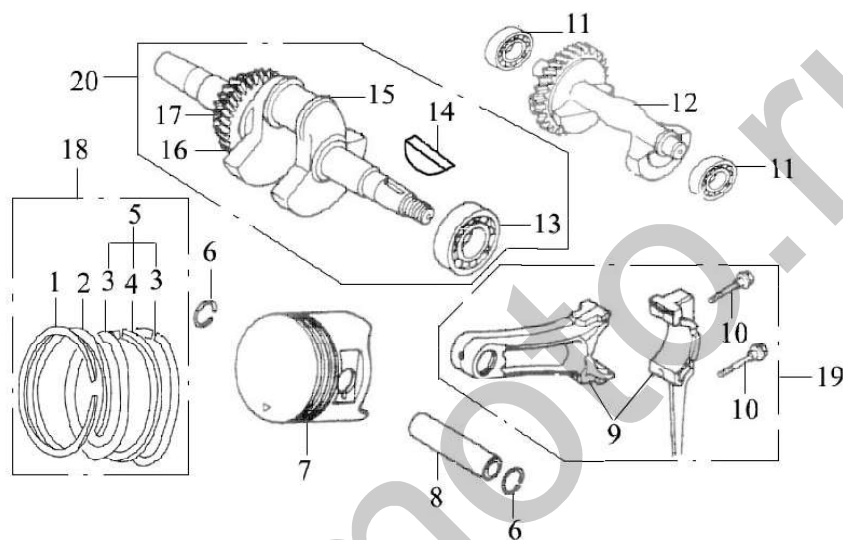

序号 S/N	零部件代号 Part No.	零部件名称	Description	数量 Quantity	备注 Remark
14	13112/173F	半圆键	Wood ruff key	1	
15	13111/182F	曲轴	Crankshaft	1	
16	13114/182F	调速主动齿轮	Drive gear	1	
17	13113/182F	正时主动齿轮	Timing driving gear	1	
18	13300	活塞环组	Piston ring set	1	
19	13200/182F	连杆组合	Connecting rod assy	1	
20	13100/182F	曲轴组合	Crankshaft assy	1	

E-5 凸轮轴装配组合 气门摇臂组合 COMBINATION OF CAM SHAFT & VALVE ROCKER

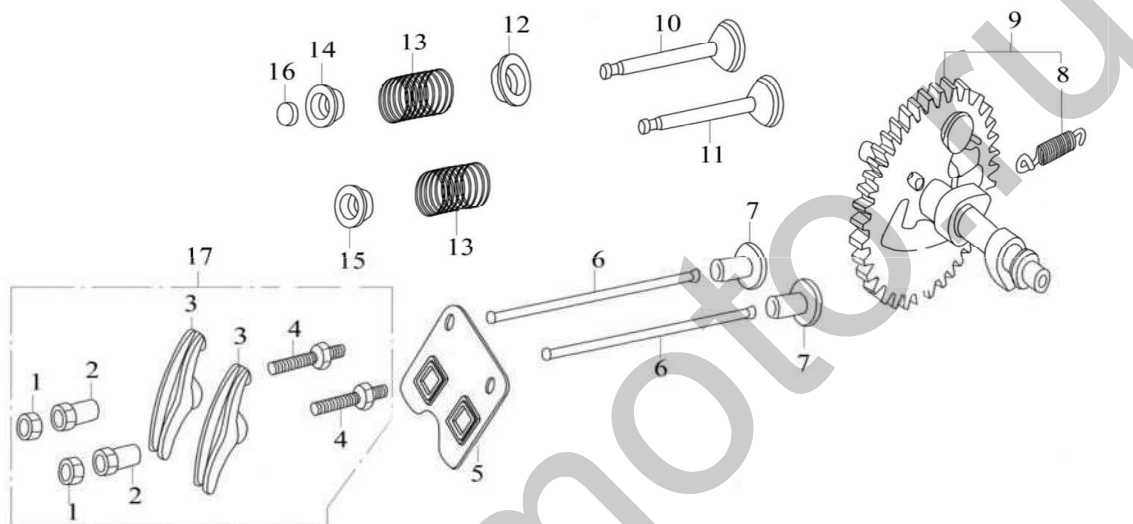

序号 S/N	零部件代号 Part No.	零部件名称	Description	数量 Quantity	备注 Remark
1	14314/173F	气门间隙调节螺母	Lock nut	2	
2	14312/173F	摇臂轴座销	Sleeve	2	
3	14311/173F	气门摇臂	Valve rocker	2	
4	14313/173F	气门间隙调节螺栓	Adjusting bolt for valve gap	2	
5	14221/173F	推杆导架	Pusher guide	1	
6	14210/182F	推杆组合	Pusher	2	
7	14315/173F	挺柱	Tappet	2	
8	14122/173F	飞块弹簧	Extension spring	1	
9	14100	凸轮轴装配组合	Camshaft assy	1	
10	14412/182F	排气门	Exhaust valve	1	
11	14411/182F	进气门	Intake valve	1	
12	14417/173F	排气门弹簧下座	Spring retainer, exhaust valve	1	
13	14414/173F	气门弹簧	Valve spring	2	
14	14415/173F	排气门弹簧座	Spring seat, exhaust valve	1	

E-5 凸轮轴装配组合 气门摇臂组合 COMBINATION OF CAM SHAFT & VALVE ROCKER

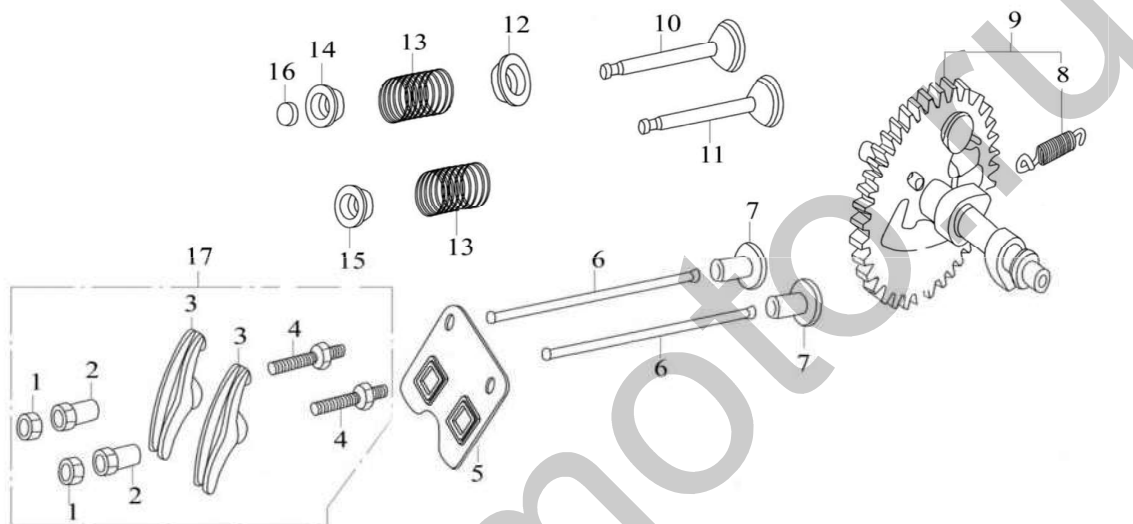

序号 S/N	零部件代号 Part No.	零部件名称	Description	数量 Quantity	备注 Remark
15	14413/173F	进气门弹簧座	Spring seat, intake valve	1	
16	14416/173F	排气门顶帽	Cap	1	
17	14310/173F	气门摇臂装配组合	Valve rocker assy	1	
				2	

E-6 化油器总成 CARBURETOR ASSY

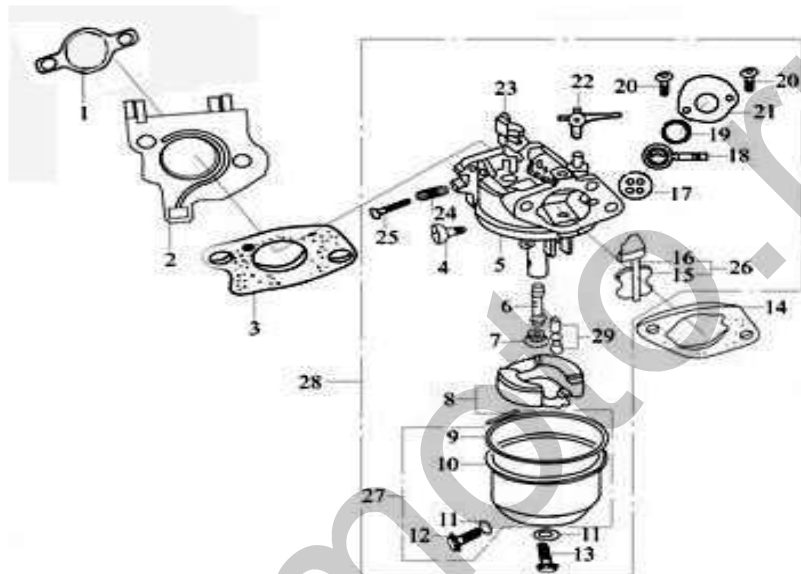

序号 S/N	零部件代号 Part No.	零部件名称	Description	数量 Quantity	备注 Remark
1	17219/182F	进气口垫片	Inlet gasket	1	
2	16112	化油器接块	Connecting block	1	
3	16113	化油器垫片	Carburetor gasket	1	
4	16351/168F	怠速调整螺钉	Idle adjustment screw	1	
5	16240	化油器混合室体	Mixture chamber body	1	
6	16244	主喷油管	Main nozzle	1	
7	16243	主喷油孔	Main jet	1	
8	16220/182F	浮子组合	Float	1	
9	16216/173F	浮子室密封垫	Float chamber gasket	1	
10	16211/173F	浮子室	Float chamber	1	
11	16215/168F	浮子室放油螺钉垫圈	Washer	2	
12	16214/168F	浮子室放油螺钉	Float chamber drain Screw	1	
13	16212/168F	浮子室螺钉	Screw	1	
14	17113/173F	空滤器垫片	Air cleaner gasket	1	

E-6 化油器总成 CARBURETOR ASSY

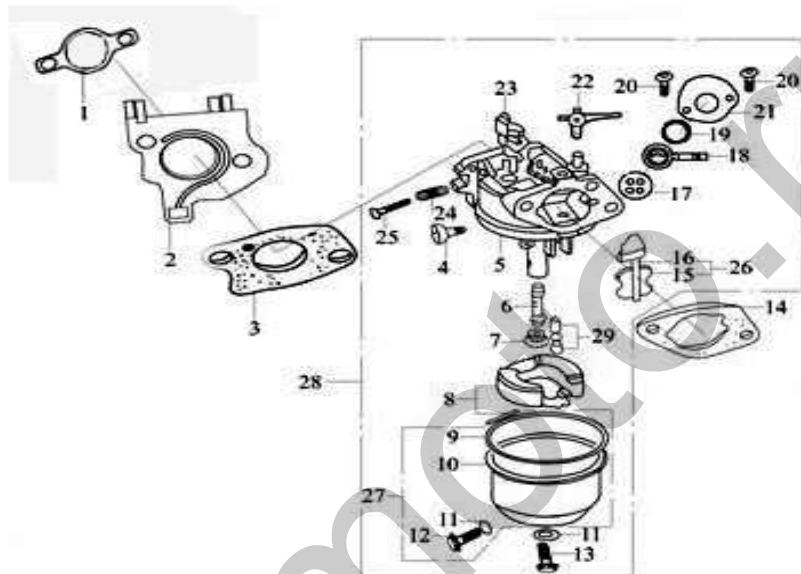

序号 S/N	零部件代号 Part No.	零部件名称	Description	数量 Quantity	备注 Remark
15	16321/173F	阻风门	Choke	1	
16	16322/173F	阻风门轴	Choke stem	1	
17	16365/168F	化油器四孔垫圈	Airproof washer	1	
18	16363/168F	化油器开关手柄	Throttle lever	1	
19	16364/168F	化油器开关密封圈	Washer	1	
20	16367	化油器开关盖螺钉	Screw M4	2	
21	16362/168F	化油器开关盖	Cover	1	
22	16114/173F	阻风门开关	Choke switch	1	
23	16250	节气门组合	Throttle unit	1	
24	16332/168F	混合比调整螺钉弹簧	Spring, mixture adjustment screw	1	
25	16331/168F	混合比调整螺钉	Mixture adjustment screw	1	
26	16320/173F	阻风门组合	Choke unit	1	
27	16210/173F	浮子室组合	Float chamber	1	
28	16100	化油器总成	Carburetor Assy	1	
29	16230/182F	浮子油针组合	Float needle	1	

E-7 燃油箱组成 FUEL TANK ASSY

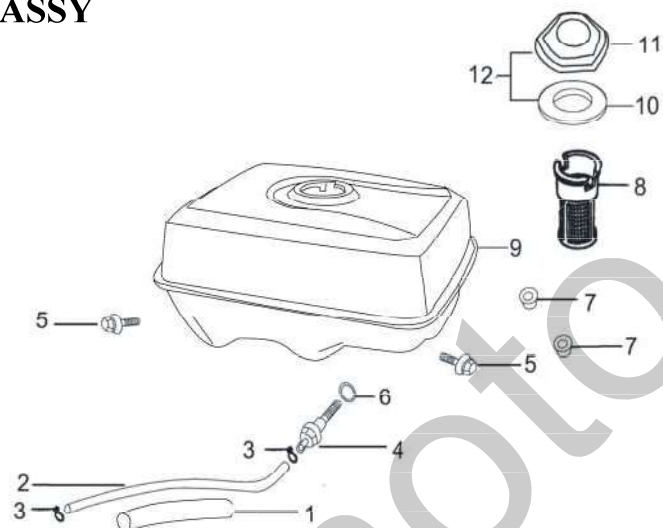

序号 S/N	零部件代号 Part No.	零部件名称	Description	数量 Quantity	备注 Remark
1	16626/173F	油管保护套	Pipe	1	
2	16621/173F	出油管 (一)	Outlet pipe	1	
3	16622/168F	油管夹 (二)	Pipe clamp	2	
4	16633/168F	出油接头	Connector	1	
5	GB5789-86	螺栓 M8×25	Bolt M8×25	2	
6	16634/168F	出油接头密封圈	Packing ring	1	
7	GB6170-2000	螺母 M8	Nut M8	2	
8	16610/168F	过滤杯	Filter cup	1	
9	16510/182F	燃油箱组件	Fuel tank	1	
10	16414/168F	密封垫圈	Packing ring	1	
11	16411/168F	燃油箱盖	Fuel filler cap	1	
12	16400/168F	燃油箱盖组合	Fuel filler cap with packing ring	1	

E-8 空气滤清器总成 AIR CLEANER ASSY

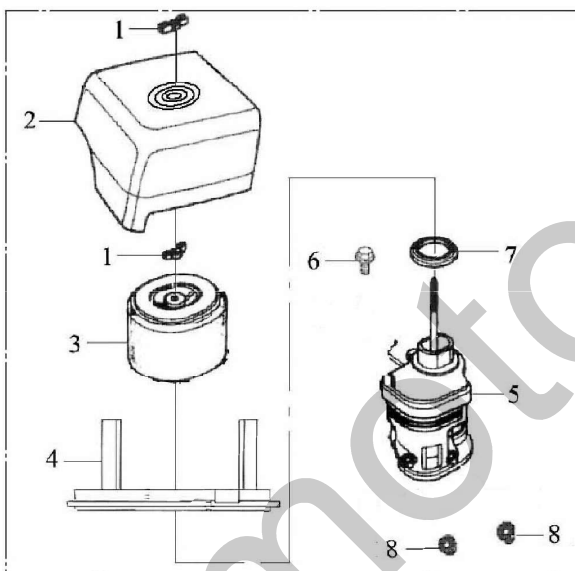

序号 S/N	零部件代号 Part No	零部件名称	Description	数量 Quantity	备注 Remark
1	17111	空滤器盖螺母	Air cleaner cover nut	2	
2	17112/182F	空滤器盖	Air cleaner cover	1	
3	17120/182F	滤芯组件	Filter element	1	
4	17114/182F	空滤器本体	Air cleaner base	1	
5	17200/173F	进气管组合	Air cleaner housing assy	1	
6	GB5789-86	空滤器座紧固螺栓 M6×22	Bolt M6×22	1	
7	17121/173F	垫圈	Washer	1	
8	GB6177.1-2000	螺母 M6(法兰)	Nut M6(Flange)	2	
9	17100/182F	空滤器总成	Air cleaner assy	1	

E-9 消声器组件 MUFFLER

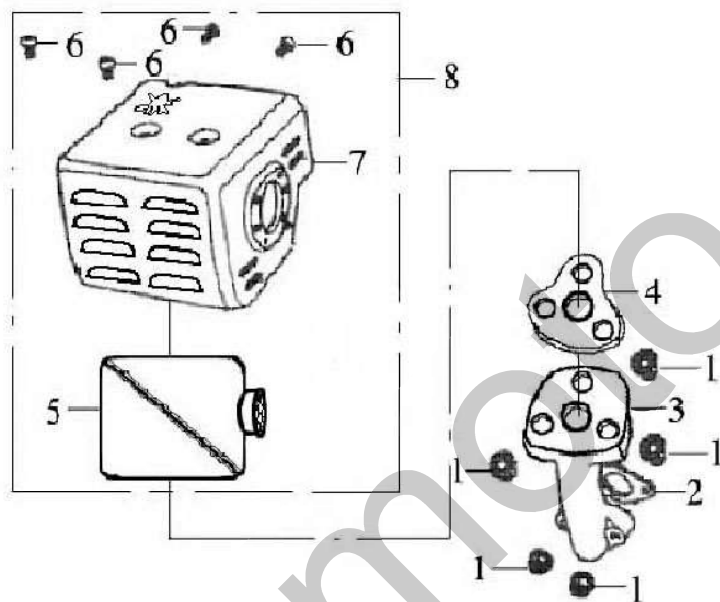

序号 S/N	零部件代号 Part No	零部件名称	Description	数量 Quantity	备注 Remark
1	GB6183-86	螺母 M8	Nut M8	5	
2	18117/173F	排气口垫片	Exhaust pipe gasket	1	
3	18215/173F	排气管	Exhaust pipe	1	
4	18217/173F	消声器垫片	Muffler gasket	1	
5	18100/182F	消声器	Muffler	1	
6	GB818-2000	螺钉 M5×8	Screw M5×8	4	
7	18200/182F	消声器护罩组合	Muffler hood assy	1	
8	18000/182F	消声器总成	Muffler assy	1	

E-10 反冲起动器部件 RECOIL STARTER

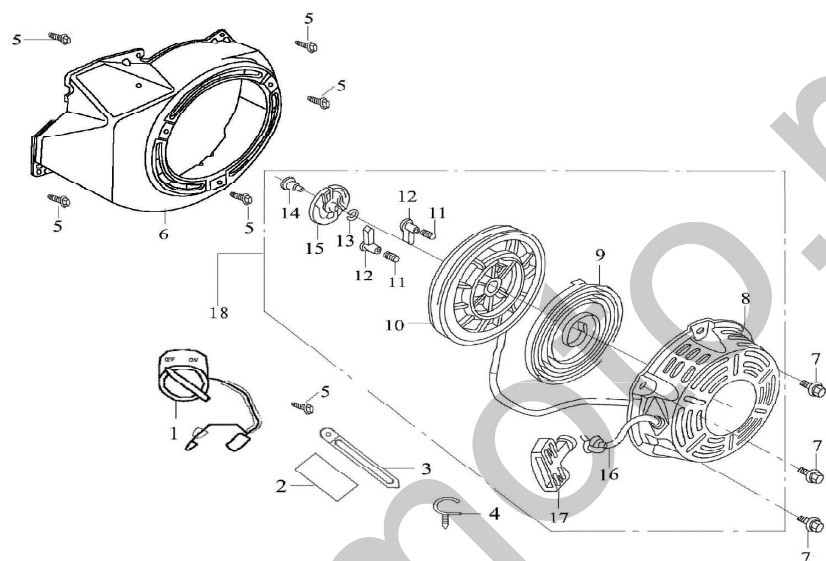

序号 S/N	零部件代号 Part No	零部件名称	Description	数量 Quantity	备注 Remark
1	31225/168F	点火开关	Engine switch	1	
2	19314/173F	护线套	Wire grommet	1	
3	19312/173F	线卡	Clip	1	
4	16625/173F	塑料管夹	Plastic clip	1	
5	GB/T16674-1996	螺栓 M6×12-F	Bolt M6×12-F	6	
6	19200/182F	风扇罩组件	Fan hood assy	1	
7	GB/T16674-1996	螺栓 M6×8-F	Bolt M6×8-F	3	
8	23211/182F	外壳组件	Casing	1	
9	23114/182F	盘簧	Spiral spring	1	
10	23117/182F	起动器卷轴	Starter rolls	1	
11	23112/173F	棘爪弹簧	Ratchet spring	2	
12	23115/173F	棘爪	Ratchet	2	
13	23111/173F	摩擦弹簧	Friction spring	1	
14	23113/173F	轴位螺钉	Set screw	1	

E-10 反冲起动器部件 RECOIL STARTER

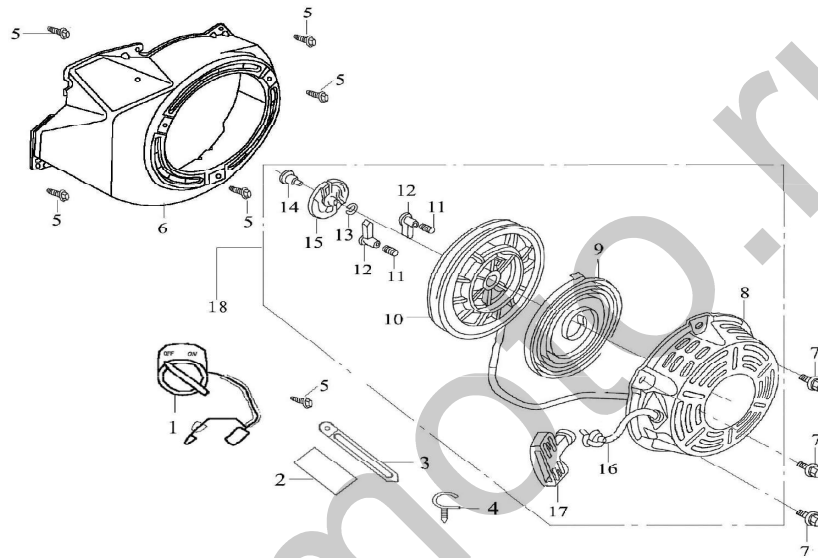

序号 S/N	零部件代号 Part No	零部件名称	Description	数量 Quantity	备注 Remark
15	23116/173F	弹簧盖	Spring lid	1	18 存在 争议
16	23118/168F	拉绳	Rope	1	
17	23121/168F	拉手	Pulling handle	1	
18	23100/182F	反冲起动器总成	Recoil starter assy	1	

E-11 调速控制系统 REGULATING CONTROL SYSTEM

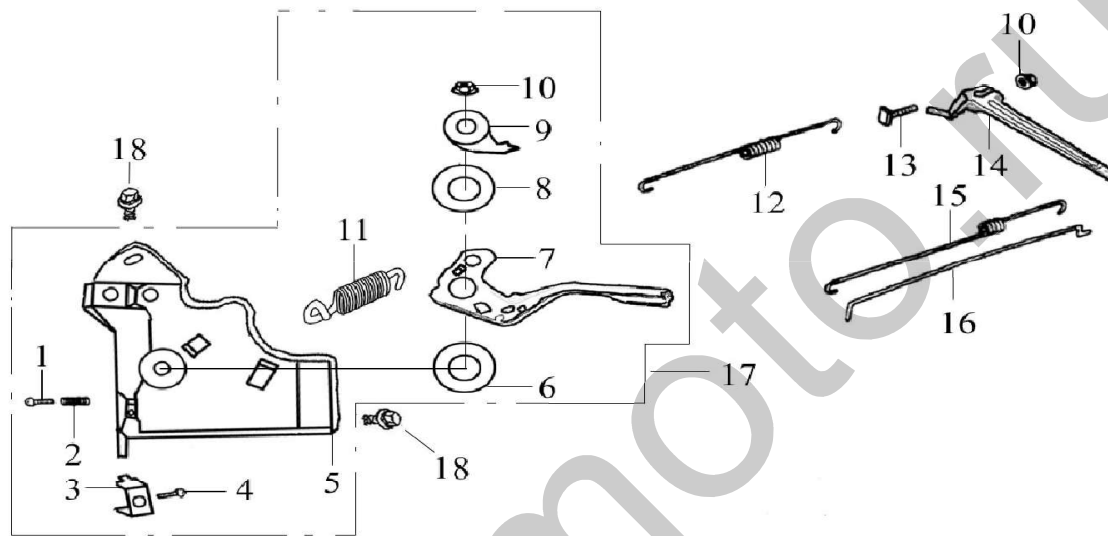

序号 S/N	零部件代号 Part No	零部件名称	Description	数量 Quantity	备注 Remark
1	GB818-2000	螺栓 M5×35	Bolt M5×35	1	
2	26215/173F	调速弹簧	Regulating spring	1	
3	26213/173F	压板	Clamp	1	
4	GB818-2000	螺栓 M5×16	Bolt M5×16	1	
5	26211/182F	调速支撑板	Support panel	1	
6	26222/173F	垫圈	Washer	1	
7	26221/182F	手柄	Handgrip	1	
8	26223/173F	弹簧片	Spring patch	1	
9	26224/173F	定位板	Setting panel	1	
10	GB6177.1-2000	螺母 M6(法兰)	Nut M6(Flange)	2	
11	26214/173F	拉簧	Spring	1	
12	26117/182F	复位弹簧	Back spring	1	
13	26116/168F	调速臂紧固螺栓	Lock bolt	1	
14	26114/182F	调速臂	Regulating arm	1	

E-11 调速控制系统 REGULATING CONTROL SYSTEM

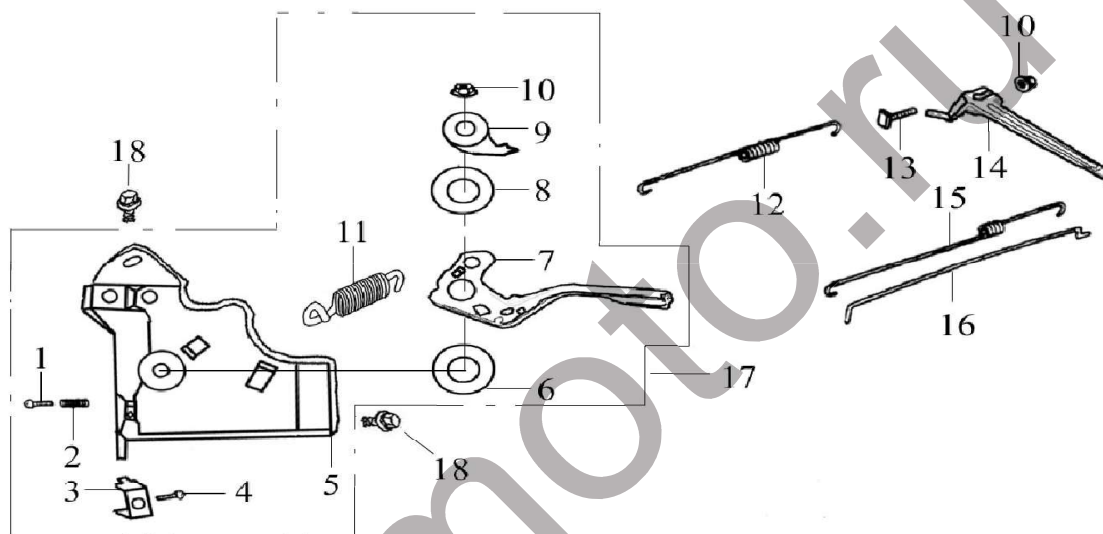

序号 S/N	零部件代号 Part No	零部件名称	Description	数量 Quantity	备注 Remark
15	26118/182F	微调速弹簧	Fine regulating spring	1	
16	26115/182F	调速拉杆	Pulling rod	1	
17	26200/182F	调速架部件	Regulating frame assy	1	
18	GB/T16674-1996	螺栓 M6×12-F	Bolt M6×12-F	2	

E-12 飞轮部件 FLYWHEEL

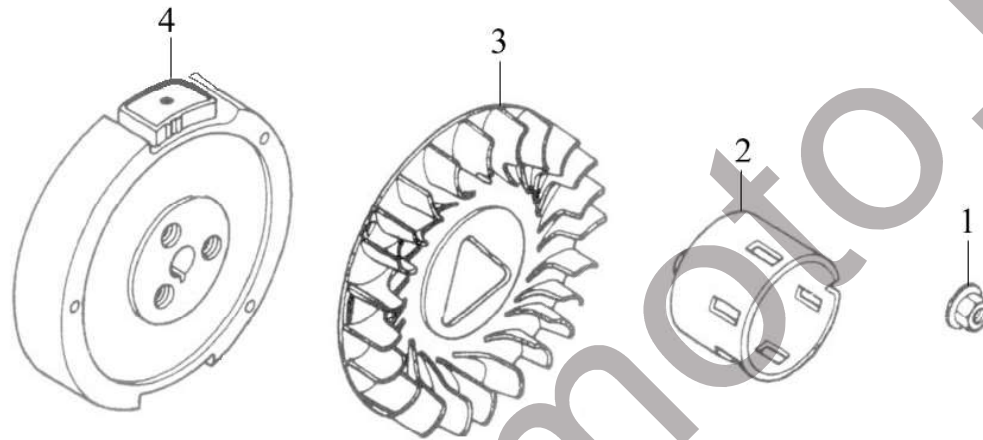

序号 S/N	零部件代号 Part No	零部件名称	Description	数量 Quantity	备注 Remark
1	23317/173F	飞轮螺母 M16×1.5	Nut M16×1.5	1	
2	23316/182F	起动套	Starting flange	1	
3	19111/182F	飞轮风扇	Flywheel fan	1	
4	23300/182F	飞轮组件	Flywheel	1	

E-13 点火线圈组件 IGNITION COIL

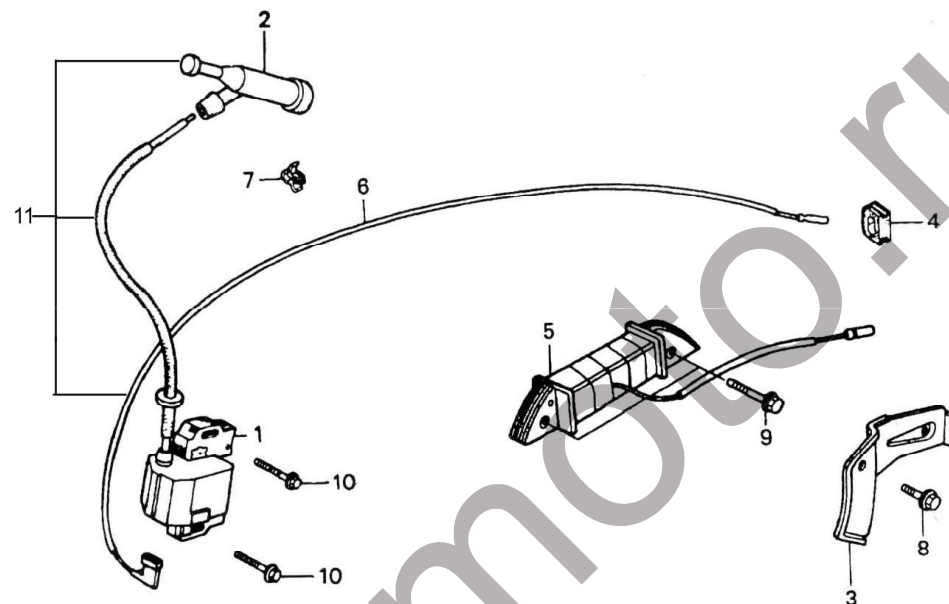

序号 S/N	零部件代号 Part No	零部件名称	Description	数量 Quantity	备注 Remark
1	27200	点火线圈	Ignition coil	1	
2	27220	火花塞帽	Cap, spark plug	1	
3	11213	压线板	Clamper, cord	1	
4	11124/173F	曲轴箱橡胶圈	Rubber ring, crankcase	1	
5	31250/182F-AS	充电定子组件	Charge coil	1	
6	34410/182F	熄火线	Extinguishing cable	1	
7	32212/173F	线夹	Cable tie	1	
8	GB5787-86	螺栓 M6×12	Bolt, M6×12	1	
9	GB5787-86	螺栓 M6×35	Bolt, M6×35	2	
10	GB5787-86	螺栓 M6×30	Bolt, M6×30	2	
11	27210	点火线圈组件	Ignition coil unit	1	

E-14 起动电机部件 Starting motor Assy

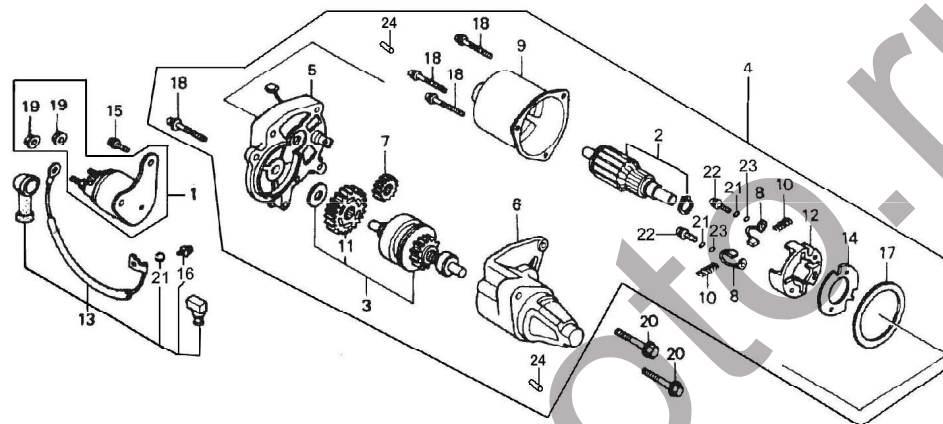

序号 S/N	零部件代号 Part No.	零部件名称	Description	数量 Quantity	备注 Remark
1	24120	起动继电器	Relay, start-up	1	
2	35200	转子组件	Rotor comp.	1	
3	21000	起动离合器	Starting clutch	1	
4	24000	电起动总成	Starting motor Assy	1	
5	28650	起动电机座	Base, starting	1	
6	28110	起动离合器壳	Housing, starting clutch	1	
7	22123	主动齿轮	Driven gear	1	
8	35230	电刷组件	Brush comp.	4	
9	35210	定子组件	Stator comp.	1	
10	28631	电刷弹簧	Spring, brush	4	
11	28321	减速齿轮	Reducing gear	1	
12	31131	电刷支架	Stay, brush	1	
13	32160	起动电机线	Cable, starting motor	1	
14	28632	绝缘块	Insulator	1	
15	31996	螺栓 M5×14	Bolt, M5×14	2	
16	GB818-85	螺钉 M4×6	Screw, M4×6	1	

E-14 起动电机部件 Starting motor Assy

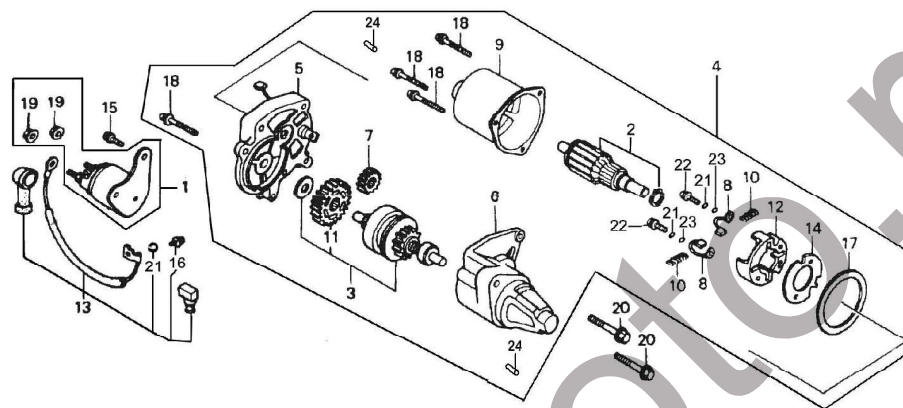

序号 S/N	零部件代号 Part No.	零部件名称	Description	数量 Quantity	备注 Remark
17	28651	密封胶圈	Packing ring	1	
18	GB818-85	螺钉 M5×32	Screw M5×32	4	
19	GB6170-86	螺母 M6	Nut M6	2	
20	GB5787-86	螺栓 M6×35	Bolt M6×35	2	
21	GB93-87	弹垫 4	Spring washer 4mm	3	
22	GB818-85	螺钉 M4×14	Screw M4×14	2	
23	GB97.1-85	平垫 4	Washer 4mm	2	
24	45315	定位销 8×14	Set pin 8×14	2	

E-15 启动控制盒总成(选用) STARTING MOTOR CONTROL BOX ASSY

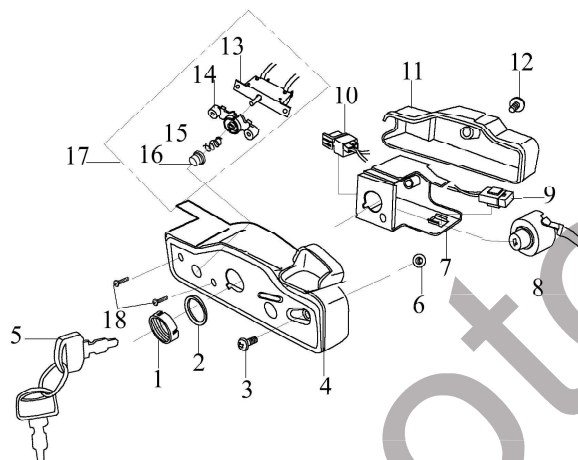

序号 S/N	零部件代号 Part No.	零部件名称	Description	数量 Quantity	备注 Remark
1	24217	锁紧圈	Clamp ring	1	
2	24218	钥匙开关垫圈	Gasket	1	
3	GB818-86	螺栓 M4×10	Bolt M4×10	1	
4	24211	控制盒前盖	Control front cover	1	
5	31258	钥匙	Key	1	
6	GB6187-86	六角法兰锁紧螺母 M4	Nut M4	1	
7	24121	控制盒内支撑架	Fixed mount	1	
8	24215	启动钥匙开关	Key switch	1	
9	24230	保险	Safety	1	
10	24225	二极管组合	Diode assy	1	
11	24213	控制盒后盖	Control rear cover	1	
12	24214	后盖连接螺栓	Attachment bolt	1	
13	24221	线路保护器	Protector	1	
14	24222	线路保护器支架	Fixed mount	1	
15	31343	弹簧	Spring	1	

E-15 启动控制盒总成(选用) STARTING MOTOR CONTROL BOX ASSY

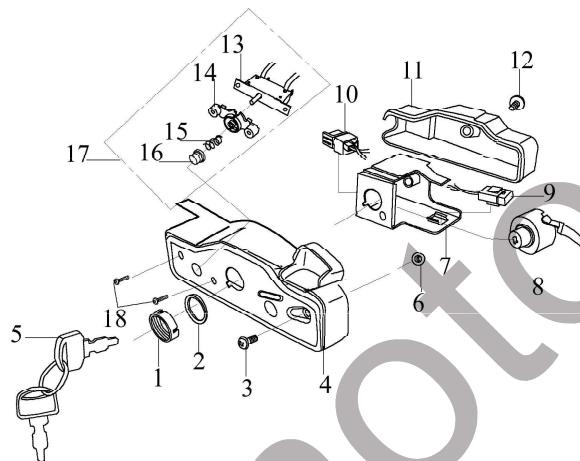

序号 S/N	零部件代号 Part No.	零部件名称	Description	数量 Quantity	备注 Remark
16	24224	线路保护器帽	Cover	1	
17	24220	线路保护器组合	Protector assy	1	
18	GB818-85	十字半圆头螺钉 M3×12	Bolt M3×12	2	

E-16 贴花 EMBLEM

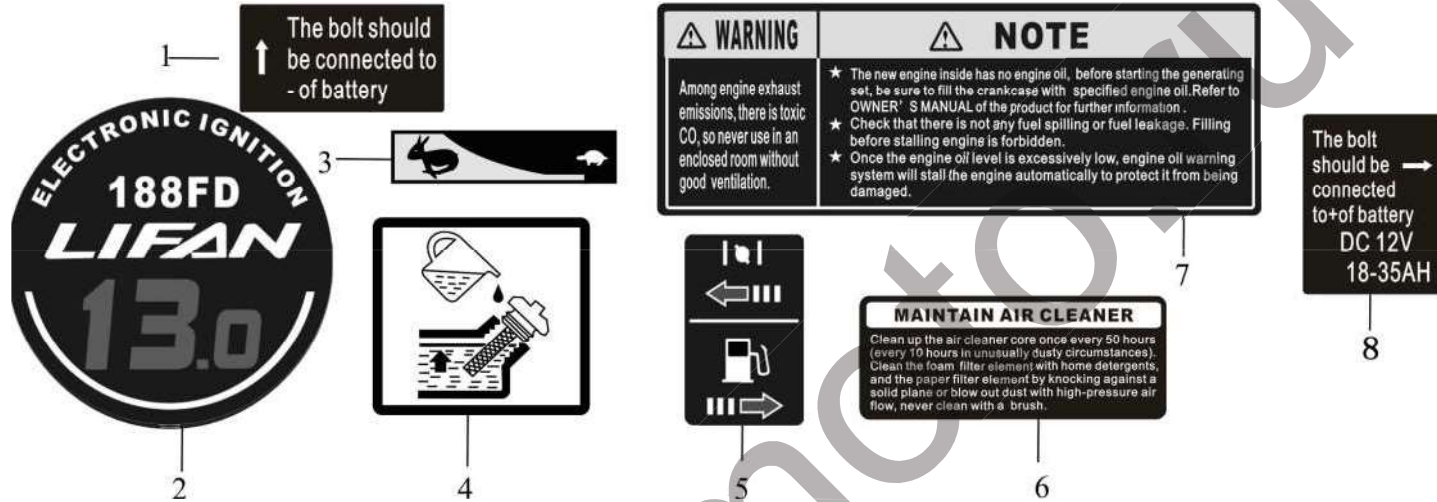

序号 S/N	零部件代号 Part No	零部件名称	Description	数量 Quantity	备注 Remark
1	91149	负极贴花	Emblem, “-” pole	1	
2	91111	型号贴花	Model label	1	
3	91114	龟兔贴花	Emblem, tortoise and rabbit	1	
4	91112	加注机油贴花	Emblem, adding oil	1	
5	91115	阻风门开关贴花	Emblem, choke lever	1	
6	91113	空滤器保养贴花	Emblem, maintenance of air cleaner	1	
7	91118	注意和警告贴花	Emblem, Note or Warning	1	
8	91148	正极贴花	Emblem, “+” pole	1	